



Document Title	HSD110PHW1 Specification	Page No.	1/27
Document No.		Revision	1.0

TO :

Date : Apr, 20, 2010

# **Customer Acceptance Specification**

**Model: HSD110PHW1**

**-A\*\***

相關文件：

Accepted by:	
Signature	Date
Proposed by: Technical Service Division	
Signature	Date

Note:

1. Please contact HannStar Display Corp. before designing your product based on this module specification.
2. The information contained herein is presented merely to indicate the characteristics and performance of our products. No responsibility is assumed by HannStar for any intellectual property claims or other problems that may result from application based on the module described herein.



Document Title	HSD110PHW1 Specification	Page No.	2/27
Document No.		Revision	1.0

### Record of Revisions

Rev.	Date	Sub-Model	Description of change
1.0	Apr, 20, 2010	A**	Tentative specification was first released



Document Title	HSD110PHW1 Specification	Page No.	3/27
Document No.		Revision	1.0

## Contents

1.0	General description .....	p.4
2.0	Absolute maximum ratings.....	p.5
3.0	Optical characteristics.....	p.6
4.0	Block diagram .....	p.10
5.0	Interface pin connection .....	p.12
6.0	Electrical characteristics .....	p.14
7.0	Reliability test items .....	p.21
8.0	Outline dimension .....	p.22
9.0	Lot mark .....	p.24
10.0	Package specification .....	p.25
11.0	General precaution .....	p.26

Document Title	HSD110PHW1 Specification	Page No.	4/27
Document No.		Revision	1.0

## 1.0 GENERAL DESCRIPTION

### 1.1 Introduction

HannStar Display model HSD110PHW1-A\*\* is a color active matrix thin film transistor (TFT) liquid crystal display (LCD) that uses amorphous silicon TFT as a switching device. This model is composed of a TFT LCD panel, a driving circuit and a back light system. This TFT LCD has a 11 (16:9) inch diagonally measured active display area with HD (1366 horizontal by 768 vertical pixel) resolution.

### 1.2 Features

- 11 (16:9 diagonal) inch configuration
- One channel LVDS interface
- 262K color by 6 bit R.G.B signal input
- RoHS Compliance
- Halogen Free

### 1.3 Applications

- NB

### 1.4 General information

Item	Specification	Unit
Outline Dimension	256(Typ) x 154.7(Typ) x 5.2 (Max)	mm
Display area	243.63(H) x 136.97(V)	mm
Number of Pixel	1366 RGB (H) x 768(V)	pixels
Pixel pitch	0.1784(H) x 0.1784(V)	mm
Pixel arrangement	RGB Vertical stripe	
Display mode	Normally white	
NTSC	50	%
Surface treatment	AG, Hard-Coating (3H)	
Weight	230 (Typ.)	g
Back-light	White LED	
Power Consumption	Logic System 1.2W (Max.)	W

Document Title	HSD110PHW1 Specification	Page No.	5/27
Document No.		Revision	1.0

### 1.5 Mechanical Information

Item		Min.	Typ.	Max.	Unit
Module Size	Horizontal (H)	255.5	256	256.5	mm
	Vertical (V)	154.2	154.7	155.2	mm
	Depth (D)	—	—	5.2	mm
Weight		—	230	240	g

## 2.0 ABSOLUTE MAXIMUM RATINGS

### 2.1 Electrical Absolute Rating

#### 2.1.1 TFT LCD Module

Item	Symbol	Min.	Max.	Unit	Note
Logic Supply voltage	$V_{DD}$	-0.3	6.0	V	

#### 2.1.2 Environment Absolute Rating

Item	Symbol	Min.	Max.	Unit	Note
Operating Temperature	$T_{opa}$	0	50	°C	
Storage Temperature	$T_{stg}$	-20	60	°C	

Document Title	HSD110PHW1 Specification	Page No.	6/27
Document No.		Revision	1.0

### 3.0 OPTICAL CHARACTERISTICS

#### 3.1 Optical specification

Item		Symbol	Condition	Min.	Typ.	Max.	Unit	Note
Contrast		CR	$\theta=0$ Normal viewing angle	400	500	—		(1)(2)(4)
Response time	Rising	Tr		—	2.4	4.8	msec	(1)(3)
	Falling	Tf		—	5.6	11.2		
White luminance (5 point)		$Y_L$		176	220	—	cd/m <sup>2</sup>	(1)(4)(5) ( $I_L=20mA$ )
Color chromaticity (CIE1931)	Red	$R_x$	$\theta=0$ Normal viewing angle	0.580	0.610	0.640		
		$R_y$		0.337	0.367	0.397		
	Green	$G_x$		0.326	0.356	0.386		
		$G_y$		0.556	0.586	0.616		
	Blue	$B_x$		0.132	0.162	0.192		
		$B_y$		0.097	0.127	0.157		
	White	$W_x$		0.283	0.313	0.343		
		$W_y$		0.299	0.329	0.359		
Viewing angle	Hor.	$\theta_L$	CR>10	40	45	—		(1)(4)
		$\theta_R$		40	45	—		
	Ver.	$\theta_U$		10	15	—		
		$\theta_D$		30	35	—		
Brightness uniformity		$B_{UNI}$	$\theta=0$ (5point)	80	—	—	%	(6)
Brightness Uniformity		$B_{UNI}$	$\theta=0$ (13 points)	70	—	—	%	(6)

#### 3.2 Measuring Condition

- Measuring surrounding : dark room
- LED current  $I_L$  : 20mA / single LED
- Ambient temperature : 25±2°C
- 15min. warm-up time.

Document Title	HSD110PHW1 Specification	Page No.	7/27
Document No.		Revision	1.0

### 3.3 Measuring Equipment

- FPM520 of Westar Display technologies, INC., which utilized SR-3 for Chromaticity and BM-5A for other optical characteristics.

- Measuring spot size : 20 ~ 21 mm

**Note (1)** Definition of Viewing Angle:

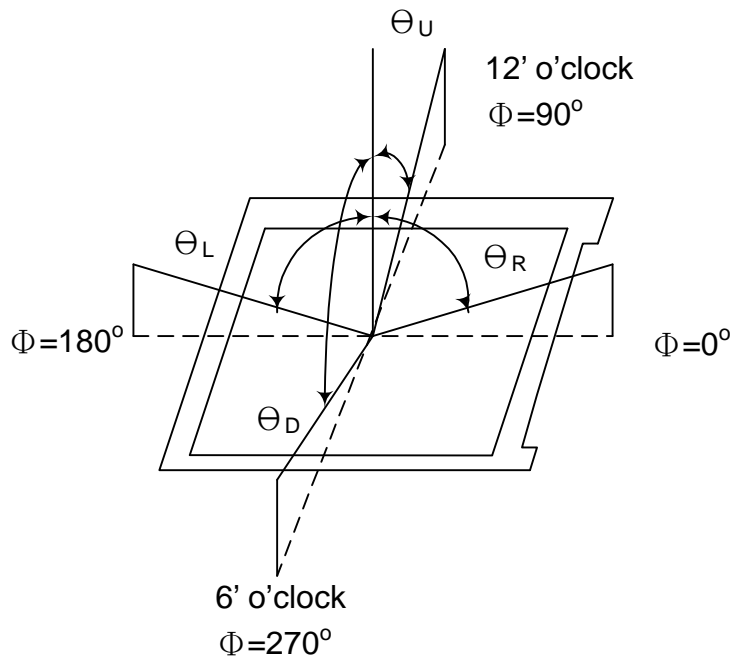

**Note (2)** Definition of Contrast Ratio (CR) :  
measured at the center point of panel

$$CR = \frac{\text{Luminance with all pixels white}}{\text{Luminance with all pixels black}}$$

Document Title	HSD110PHW1 Specification	Page No.	8/27
Document No.		Revision	1.0

**Note (3)** Definition of Response Time : Sum of  $T_R$  and  $T_F$

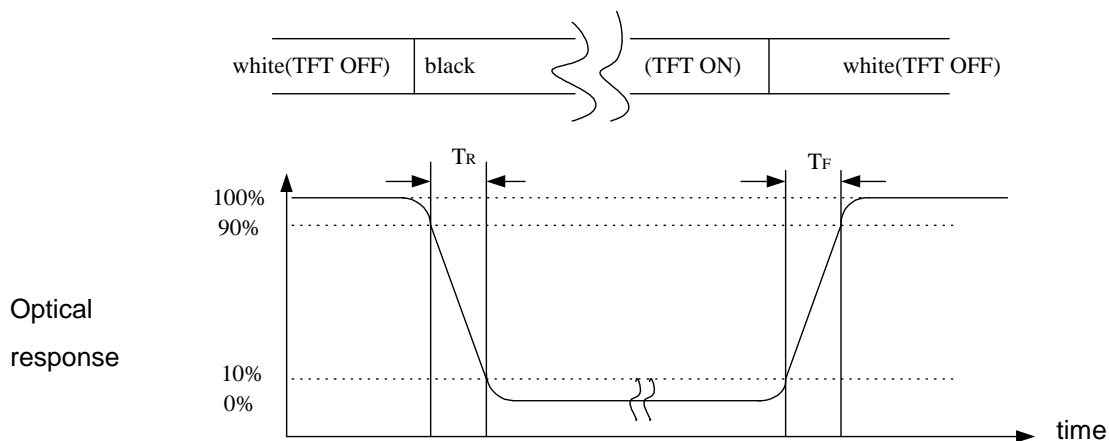

**Note (4)** Definition of optical measurement setup

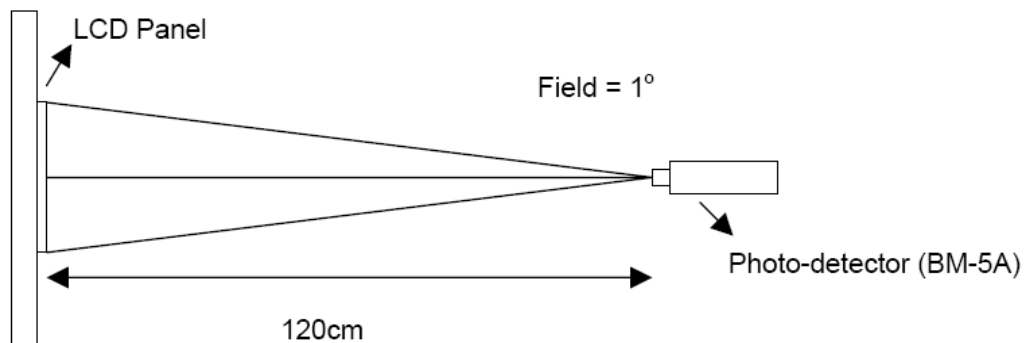

Document Title	HSD110PHW1 Specification	Page No.	9/27
Document No.		Revision	1.0

**Note (5)** Definition of Average Luminance Uniformity of White (5 Point)

$$\text{Average Luminance Uniformity} = \frac{Y_1+Y_2+Y_3+Y_4+Y_5}{5}$$

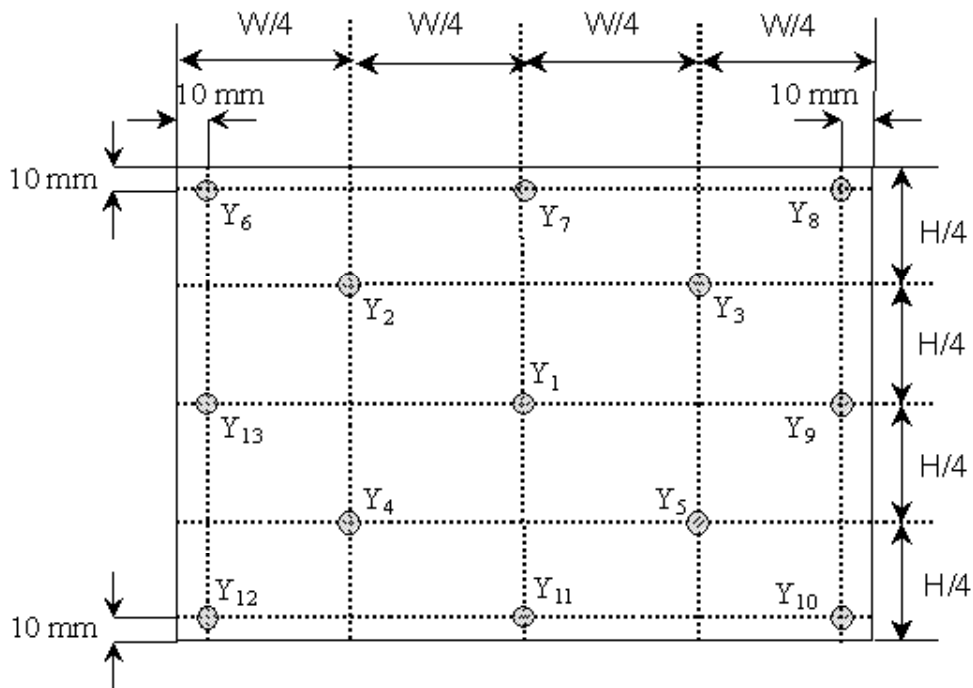

**Note (6)** Definition of brightness uniformity

$$\text{Luminance uniformity(5 points)} = \frac{(\text{Min Luminance of 5 points})}{(\text{Max Luminance of 5 points})} \times 100\%$$

$$\text{Luminance uniformity(13points)} = \frac{(\text{Min Luminance of 13 points})}{(\text{Max Luminance of 13 points})} \times 100\%$$

Document Title	HSD110PHW1 Specification	Page No.	10/27
Document No.		Revision	1.0

### 4.0 BLOCK DIAGRAM

#### 4.1 TFT LCD Module:

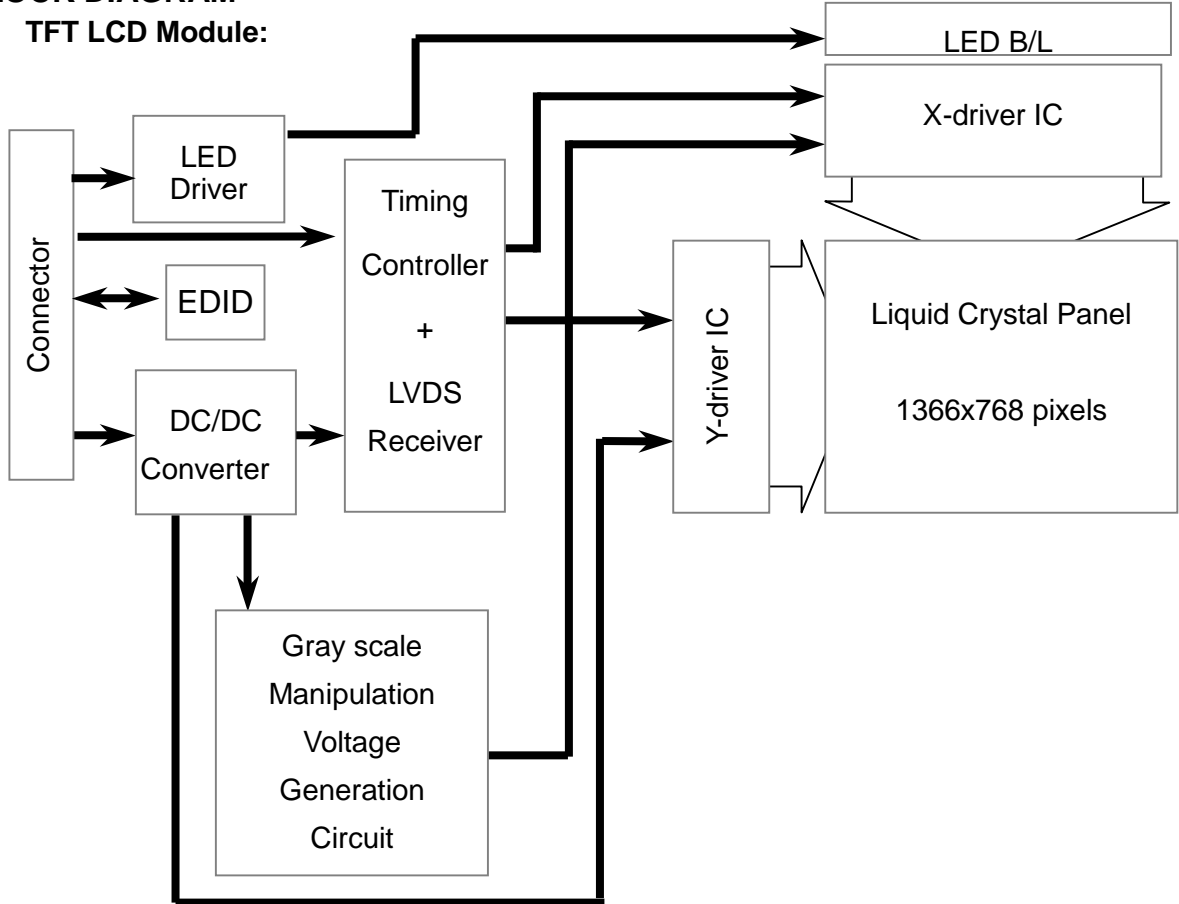

#### 4.2 Pixel Format

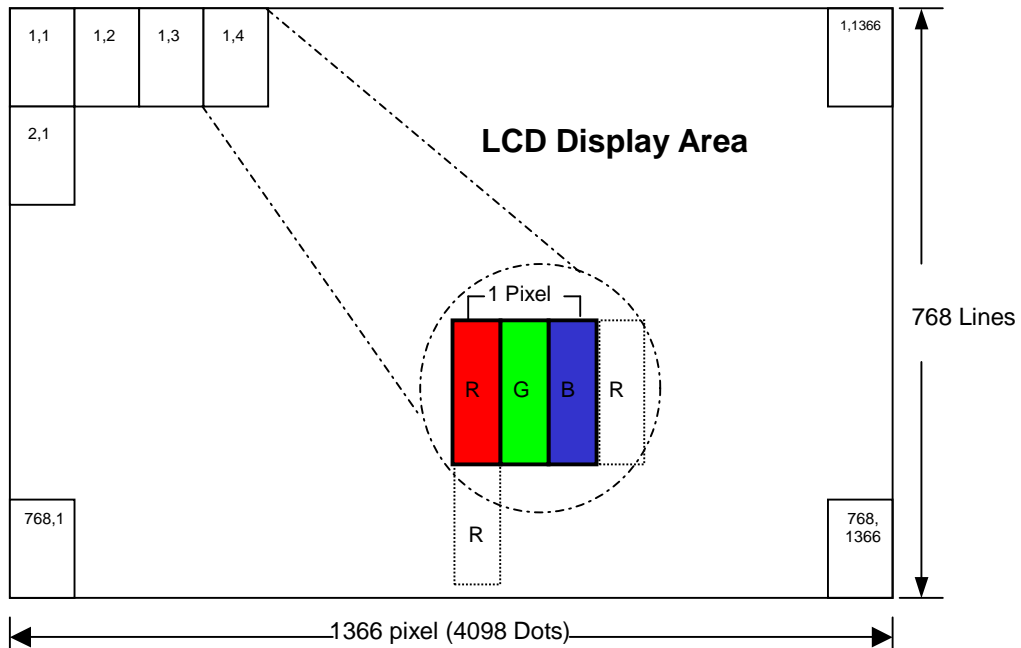

Document Title	HSD110PHW1 Specification	Page No.	11/27
Document No.		Revision	1.0

### 4.3 Relationship Between Displayed Color and Input

Display	MSB						LSB						MSB						LSB						Gray scale level
	R5	R4	R3	R2	R1	R0	G5	G4	G3	G2	G1	G0	B5	B4	B3	B2	B1	B0							
Basic color	Black	L	L	L	L	L	L	L	L	L	L	L	L	L	L	L	L	L	L	-					
	Blue	L	L	L	L	L	L	L	L	L	L	L	L	H	H	H	H	H	H	-					
	Green	L	L	L	L	L	L	H	H	H	H	H	H	L	L	L	L	L	L	-					
	Light Blue	L	L	L	L	L	L	H	H	H	H	H	H	H	H	H	H	H	H	-					
	Red	H	H	H	H	H	H	L	L	L	L	L	L	L	L	L	L	L	L	-					
	Purple	H	H	H	H	H	H	L	L	L	L	L	L	H	H	H	H	H	H	-					
	Yellow	H	H	H	H	H	H	H	H	H	H	H	H	L	L	L	L	L	L	-					
	White	H	H	H	H	H	H	H	H	H	H	H	H	H	H	H	H	H	H	-					
Gray scale of Red	Black	L	L	L	L	L	L	L	L	L	L	L	L	L	L	L	L	L	L	L0					
	Dark ↑ ↓ Light	L	L	L	L	L	H	L	L	L	L	L	L	L	L	L	L	L	L	L1					
		L	L	L	L	H	L	L	L	L	L	L	L	L	L	L	L	L	L	L2					
		⋮	⋮	⋮	⋮	⋮	⋮	⋮	⋮	⋮	⋮	⋮	⋮	⋮	⋮	⋮	⋮	⋮	⋮	L3...L60					
		H	H	H	H	L	H	L	L	L	L	L	L	L	L	L	L	L	L	L61					
	H	H	H	H	H	L	L	L	L	L	L	L	L	L	L	L	L	L	L62						
	Red	H	H	H	H	H	H	L	L	L	L	L	L	L	L	L	L	L	L	Red L63					
	Gray scale of Green	Black	L	L	L	L	L	L	L	L	L	L	L	L	L	L	L	L	L	L	L0				
Dark ↑ ↓ Light		L	L	L	L	L	L	L	L	L	L	L	H	L	L	L	L	L	L	L1					
		L	L	L	L	L	L	L	L	L	L	H	L	L	L	L	L	L	L	L2					
		⋮	⋮	⋮	⋮	⋮	⋮	⋮	⋮	⋮	⋮	⋮	⋮	⋮	⋮	⋮	⋮	⋮	⋮	L3...L60					
		L	L	L	L	L	L	H	H	H	H	L	H	L	L	L	L	L	L	L61					
L		L	L	L	L	L	H	H	H	H	H	L	L	L	L	L	L	L	L62						
Green		L	L	L	L	L	L	H	H	H	H	H	H	L	L	L	L	L	Green L63						
Gray scale of Blue		Black	L	L	L	L	L	L	L	L	L	L	L	L	L	L	L	L	L	L	L0				
	Dark ↑ ↓ Light	L	L	L	L	L	L	L	L	L	L	L	L	L	L	L	L	L	H	L1					
		L	L	L	L	L	L	L	L	L	L	L	L	L	L	L	L	H	L	L2					
		⋮	⋮	⋮	⋮	⋮	⋮	⋮	⋮	⋮	⋮	⋮	⋮	⋮	⋮	⋮	⋮	⋮	⋮	L3...L60					
		L	L	L	L	L	L	L	L	L	L	L	L	H	H	H	H	L	H	L61					
	L	L	L	L	L	L	L	L	L	L	L	L	H	H	H	H	H	L	L62						
	Blue	L	L	L	L	L	L	L	L	L	L	L	L	H	H	H	H	H	Blue L63						
	Gray scale of White & Black	Black	L	L	L	L	L	L	L	L	L	L	L	L	L	L	L	L	L	L	L0				
Dark ↑ ↓ Light		L	L	L	L	L	H	L	L	L	L	L	H	L	L	L	L	L	H	L1					
		L	L	L	L	H	L	L	L	L	L	H	L	L	L	L	L	H	L	L2					
		⋮	⋮	⋮	⋮	⋮	⋮	⋮	⋮	⋮	⋮	⋮	⋮	⋮	⋮	⋮	⋮	⋮	⋮	L3...L60					
		H	H	H	H	L	H	H	H	H	H	L	H	H	H	H	H	L	H	L61					
H		H	H	H	H	L	H	H	H	H	H	L	H	H	H	H	H	L	L62						
White		H	H	H	H	H	H	H	H	H	H	H	H	H	H	H	H	H	White L63						

Document Title	HSD110PHW1 Specification	Page No.	12/27
Document No.		Revision	1.0

## 5.0 INTERFACE PIN CONNECTION

### 5.1 TFT LCD Module : CN1 (Input signal): FI-XB30SL-HF10 (JAE or equivalent)

Pin No.	Signal	Description
1	GND	Ground
2	VDD	3.3V Power
3	VDD	3.3V Power
4	V_EDID	3.3V Power for EDID
5	PWM	System PWM Signal Input
6	CLK_EDID	EDID Clock Input
7	DATA_EDID	EDID Data Input
8	RXIN0-	LVDS Signal - channel0-
9	RXIN0+	LVDS Signal+ channel0+
10	GND	Ground
11	RXIN1-	Data Input channel1-
12	RXIN1+	Data Input channel1+
13	GND	Ground
14	RXIN2-	Data Input channel2-
15	RXIN2+	Data Input channel2+
16	GND	Ground
17	RXCLKIN-	Data Input CLK-
18	RXCLKIN+	Data Input CLK+
19	GND	Ground
20	NC	NC
21	NC	NC
22	GND	Ground
23	GND	Ground
24	VLED	LED Input voltage 5V~21V
25	VLED	LED Input voltage 5V~21V
26	VLED	LED Input voltage 5V~21V
27	LED_EN	LED Enable Signal
28	NC	NC
29	NC	NC
30	NC	NC

**Note : The brightness of LCD panel could be changed by adjusting PWM**

Document Title	HSD110PHW1 Specification	Page No.	13/27
Document No.		Revision	1.0

## 6.0 ELECTRICAL CHARACTERISTICS

### 6.1 TFT LCD Module

Item	Symbol	Min.	Typ.	Max.	Unit	Note
Supply Voltage	$V_{DD}$	3.0	3.3	3.6	V	Note (2)
Current of power supply	$I_{DD}$	-	0.3	-	A	$V_{DD}=3.3V$ · L0 pattern
Inrush current	$I_{RUSH}$	-	-	1.50	A	Note (2)

**Note (1):**  $V_{DD}$ -dip condition:

When  $V_{DD}$  operating within  $2.7V \leq V_{DD} < 3.0V$  ,  $t_d \leq 10ms$  , the display may momentarily become abnormal.

$V_{DD} < 2.7V$  ,  $V_{DD}$  dip condition should also follow the Power On/Off conditions for supply voltage.

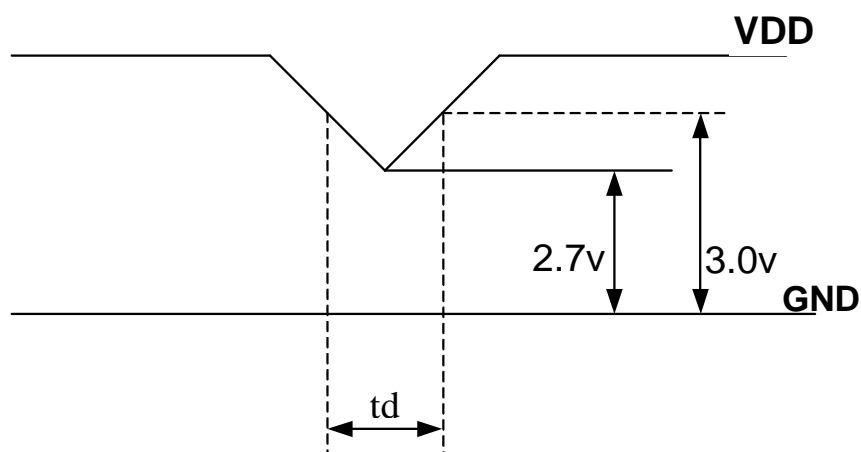

Document Title	HSD110PHW1 Specification	Page No.	14/27
Document No.		Revision	1.0

**Note : (2) Power on Inrush current test circuit**

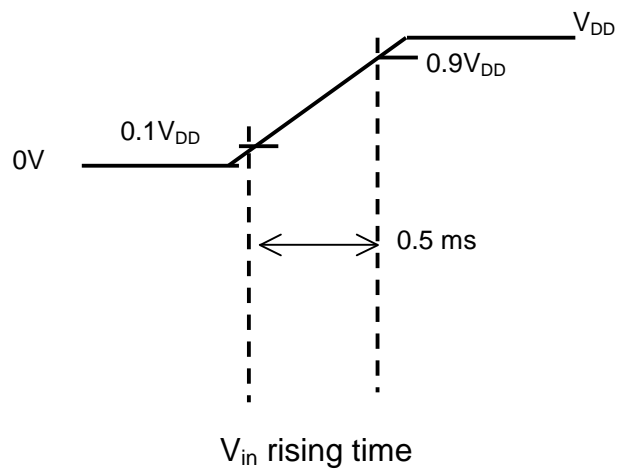
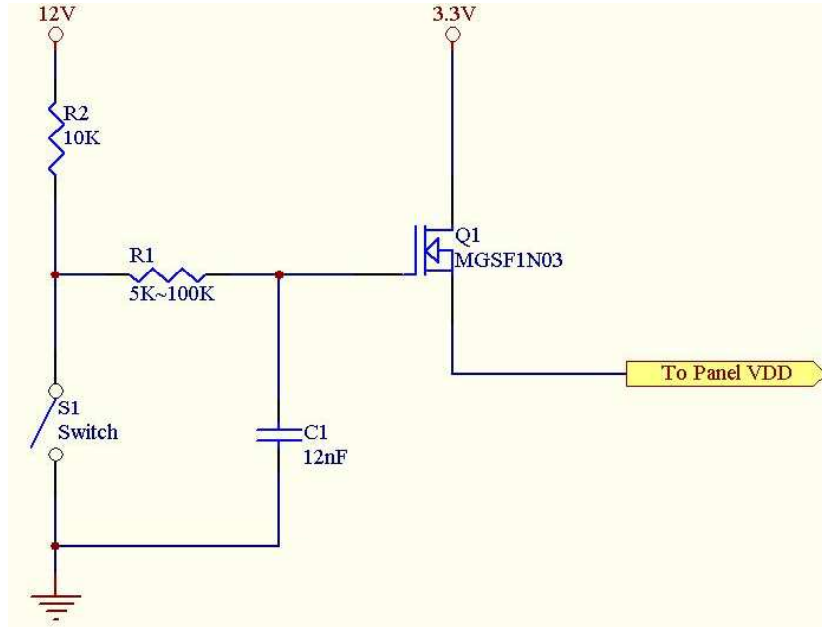

Document Title	HSD110PHW1 Specification	Page No.	15/27
Document No.		Revision	1.0

### 6.2 Switching Characteristics for LVDS Receiver

Item	Symbol	Min.	Typ.	Max.	Unit	Conditions
Differential Input High Threshold	V <sub>th</sub>	—	—	100	mV	V <sub>CM</sub> =1.2V
Differential Input Low Threshold	V <sub>tl</sub>	-100	—	—	mV	
Input Current	I <sub>IN</sub>	-10	—	+10	uA	
Differential input Voltage	V <sub>ID</sub>	0.1	—	0.6	V	
Common Mode Voltage Offset	V <sub>CM</sub>	( V <sub>ID</sub>  /2)	1.25	1.8-0.4-( V <sub>ID</sub>  /2)	V	

### 6.3 Bit Mapping & Interface Definition

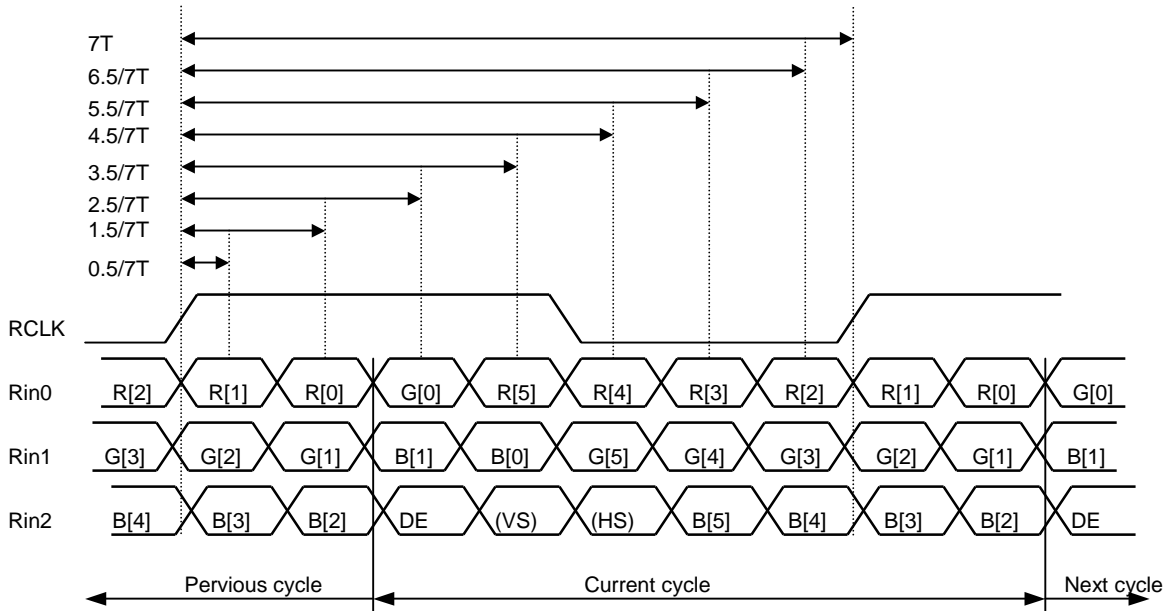

LVDS Receiver Input Timing Definition  
for 6bits LVDS input

Document Title	HSD110PHW1 Specification	Page No.	16/27
Document No.		Revision	1.0

### 6.4 Interface Timing (DE mode)

Item	Symbol	Min.	Typ.	Max.	Unit
Frame Rate	--	55	60	-	Hz
Frame Period	t1	778	806	888	line
Vertical Display Time	t2	768	768	768	line
Vertical Blanking Time	t3	10	38	120	line
1 Line Scanning Time	t4	1437	1560	1936	clock
Horizontal Display Time	t5	1366	1366	1366	clock
Horizontal Blanking Time	t6	71	194	570	clock
Clock Rate	t7	50.3	75.44	80	MHz

### Timing Diagram of Interface Signal (DE mode)

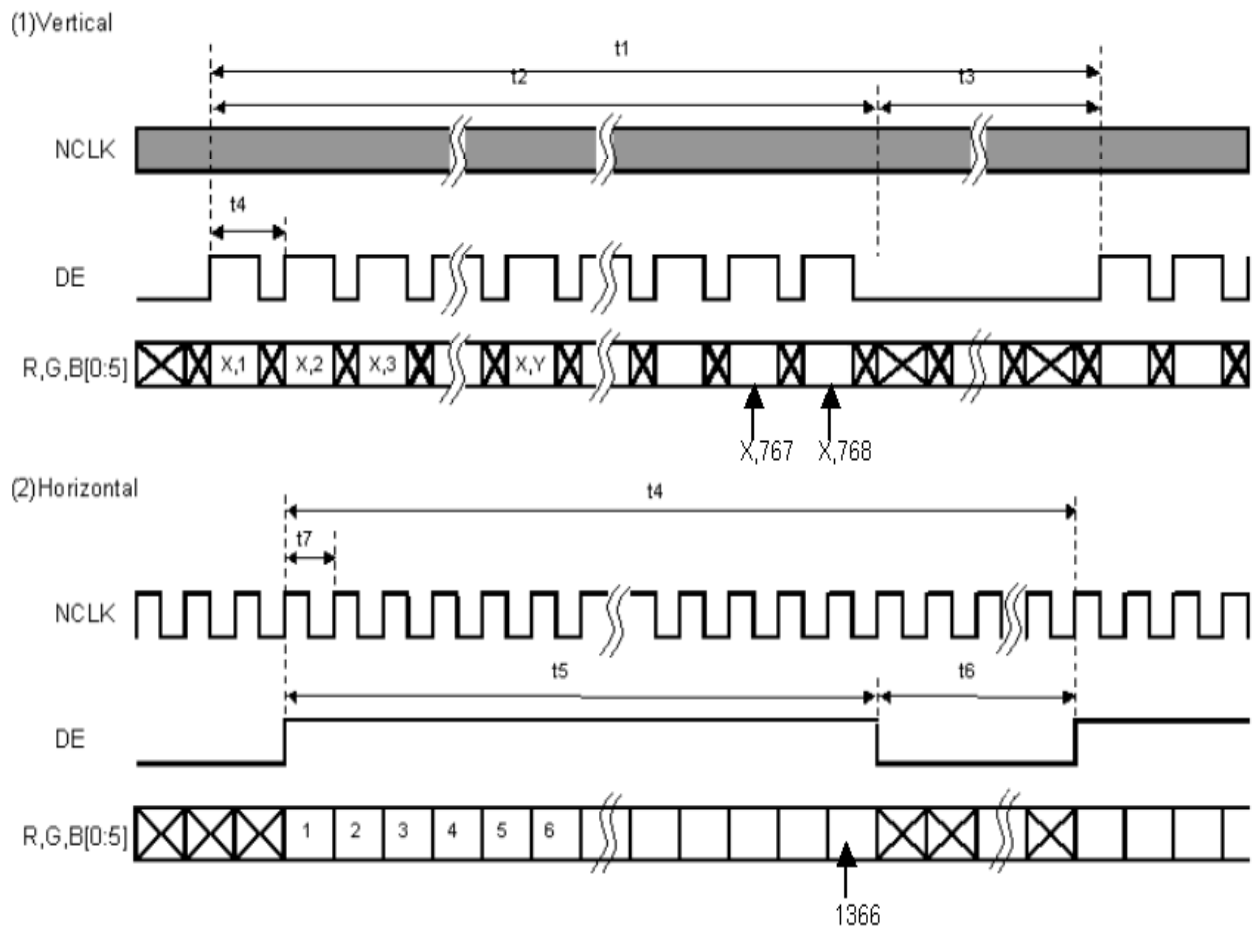

Document Title	HSD110PHW1 Specification	Page No.	17/27
Document No.		Revision	1.0

### 6.5 Power On / Off Sequence

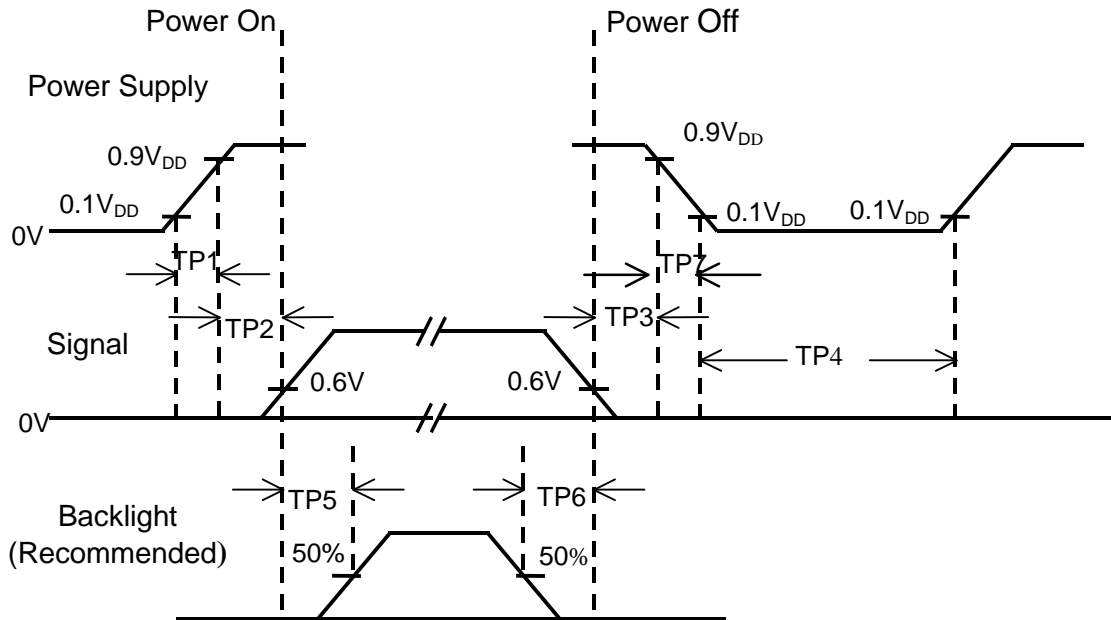

Item	Min.	Typ.	Max.	Unit	Remark
TP1	0.5	--	10	msec	
TP2	0	--	50	msec	
TP3	0	--	50	msec	
TP4	1000	--	--	msec	
TP5	200	--	--	msec	
TP6	200	--	--	msec	
TP7	0.5	--	10	msec	

- Note :**
- (1) The supply voltage of the external system for the module input should be the same as the definition of V<sub>DD</sub>.
  - (2) Apply the lamp voltage within the LCD operation range. When the back-light turns on before the LCD operation or the LCD turns off before the back-light turns off, the display may momentarily become white.
  - (3) In case of V<sub>DD</sub> = off level, please keep the level of input signal on the low or keep a high impedance.
  - (4) TP4 should be measured after the module has been fully discharged between power off and on period.
  - (5) Interface signal shall not be kept at high impedance when the power is on.

Document Title	HSD110PHW1 Specification	Page No.	18/27
Document No.		Revision	1.0

## 6.6 Backlight Unit

Parameter	Symbol	Min	Typ	Max	Units	Condition
LED Current	$I_F$	--	20	20.6	mA	Ta=25°C
LED Voltage	$V_F$	3.0	3.2	3.4	Volt	Ta=25°C
LED Power consumption	$P_{LED}$	--	1.92	2.1	Watt	Ta=25°C Note (1)
LED Life-Time	N/A	10,000	--	--	Hour	Ta=25°C $I_F=20mA$ Note (2)

**Note (1):** Calculator value for reference  $P=I_F \times V_F \times N$  (LED Qty')

**Note (2):** The LED lifetime defines as the estimated time to 50% degradation of final luminous.

## 6.7 LED Driver

### 6.7.1 Absolute Maximum Ratings

Item	Symbol	Min.	Max.	Unit	Note
LED Power Supply voltage	$V_{LED}$	-0.3	24	Volt	
LED_EN, PWM pin Voltage	$V_{EN}, V_{PWM}$	--	5.5	Volt	

### 6.7.2 DC Electrical Characteristics

Parameter	Symbol	Min	Typ	Max	Units	Remark
LED Power Supply Voltage	$V_{LED}$	5.0	--	21.0	Volt	
LED_EN High Threshold	$V_{ENH}$	2.0	--	--	Volt	
LED_EN Low Threshold	$V_{ENL}$	--	--	0.3	Volt	
PWM High Threshold	$V_{PWMH}$	3.0	--	--	Volt	
PWM Low Threshold	$V_{PWML}$	--	--	0.2	Volt	
PWM Frequency	$F_{PWM}$	225	250	275	Hz	
PWM Duty Cycle	$T_D$	10	--	100	%	Note(1)

Document Title	HSD110PHW1 Specification	Page No.	19/27
Document No.		Revision	1.0

**Note (1): PWM Duty Cycle**

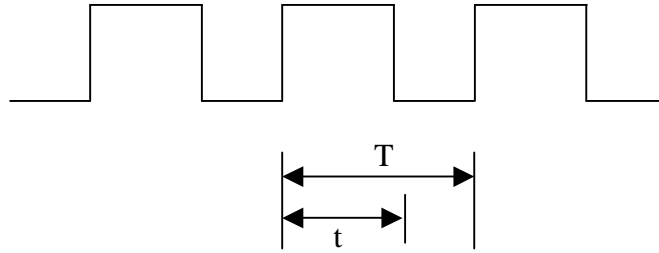

$$\text{Duty Cycle} = (t / T) * 100\%$$

**6.7.3 LED Power on/off sequence**

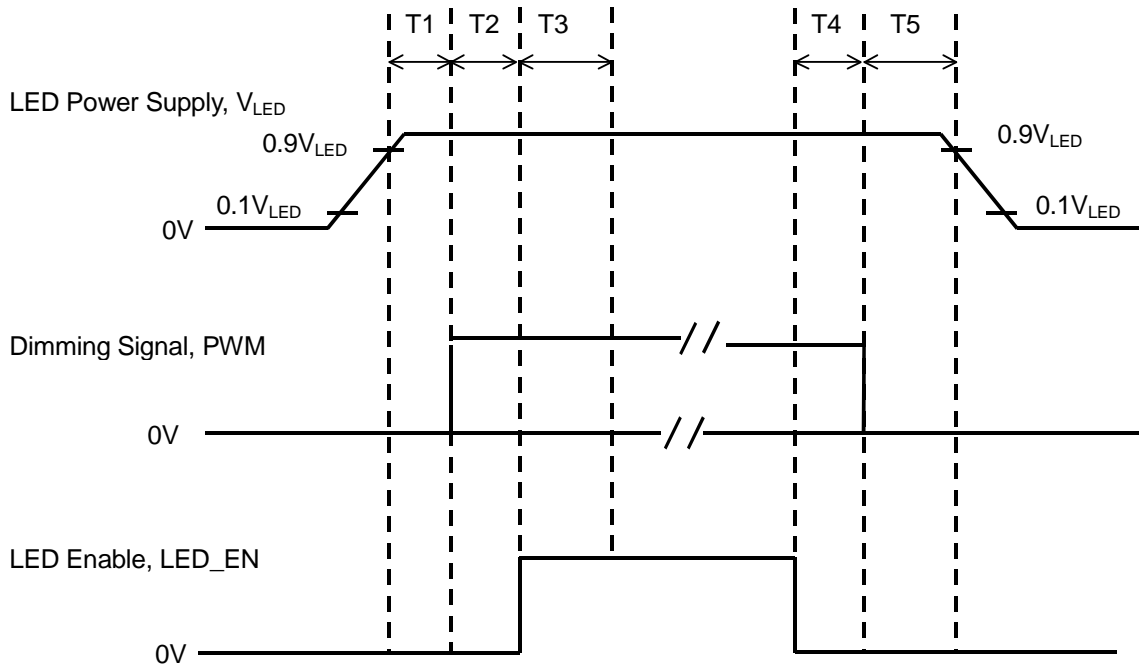



Document Title	HSD110PHW1 Specification	Page No.	20/27
Document No.		Revision	1.0

Symbol	Value			Unit
	Min	Typ	Max	
T1	10	--	--	ms
T2	10	--	--	
T3	50	--	--	
T4	0	--	--	
T5	10	--	--	

**Note (1):** The duty of LED dimming signal should be more than 20% in T2 and T3

**Note (2):** PWM can adjust brightness to control Pin. Pulse duty the bigger the brighter

Document Title	HSD110PHW1 Specification	Page No.	21/27
Document No.		Revision	1.0

### 7.0 Reliability test items

No.	Item	Conditions	Remark
1	High Temperature Storage	Ta=+60°C, 240hrs	
2	Low Temperature Storage	Ta=-20°C, 240hrs	
3	High Temperature Operation	Ta=+50°C, 500hrs	
4	Low Temperature Operation	Ta=0°C, 500hrs	
5	Thermal Cycling Test (non operation)	-20°C(30min)→+60°C(30min),100 cycles	
6	Vibration	Sine Wave 1.5G, 5~500Hz, XYZ 30min/each direction	
7	Shock	Half-Sine, 200G, 2ms, ±XYZ, 1time	

#### Storage / Operating temperature

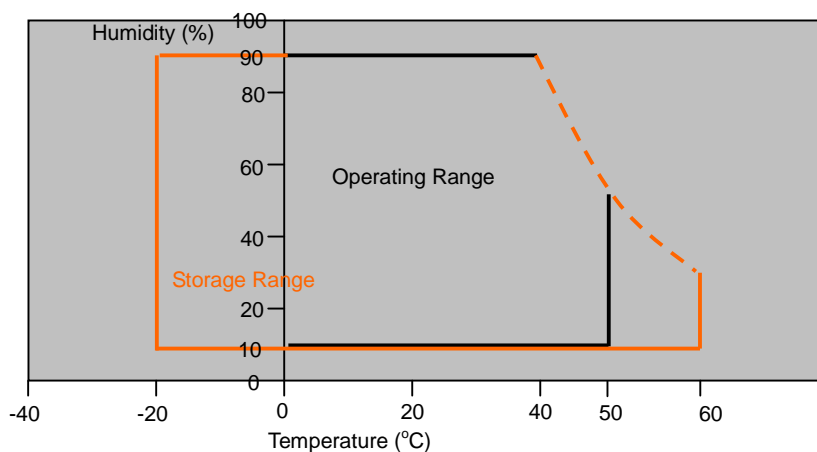

**Note** .Max wet bulb temp.=39°C

Document Title	HSD110PHW1 Specification	Page No.	22/27
Document No.		Revision	1.0

### 8.0 OUTLINE DIMENSION

#### 8.1 Front View Outline Dimension

Unit : mm

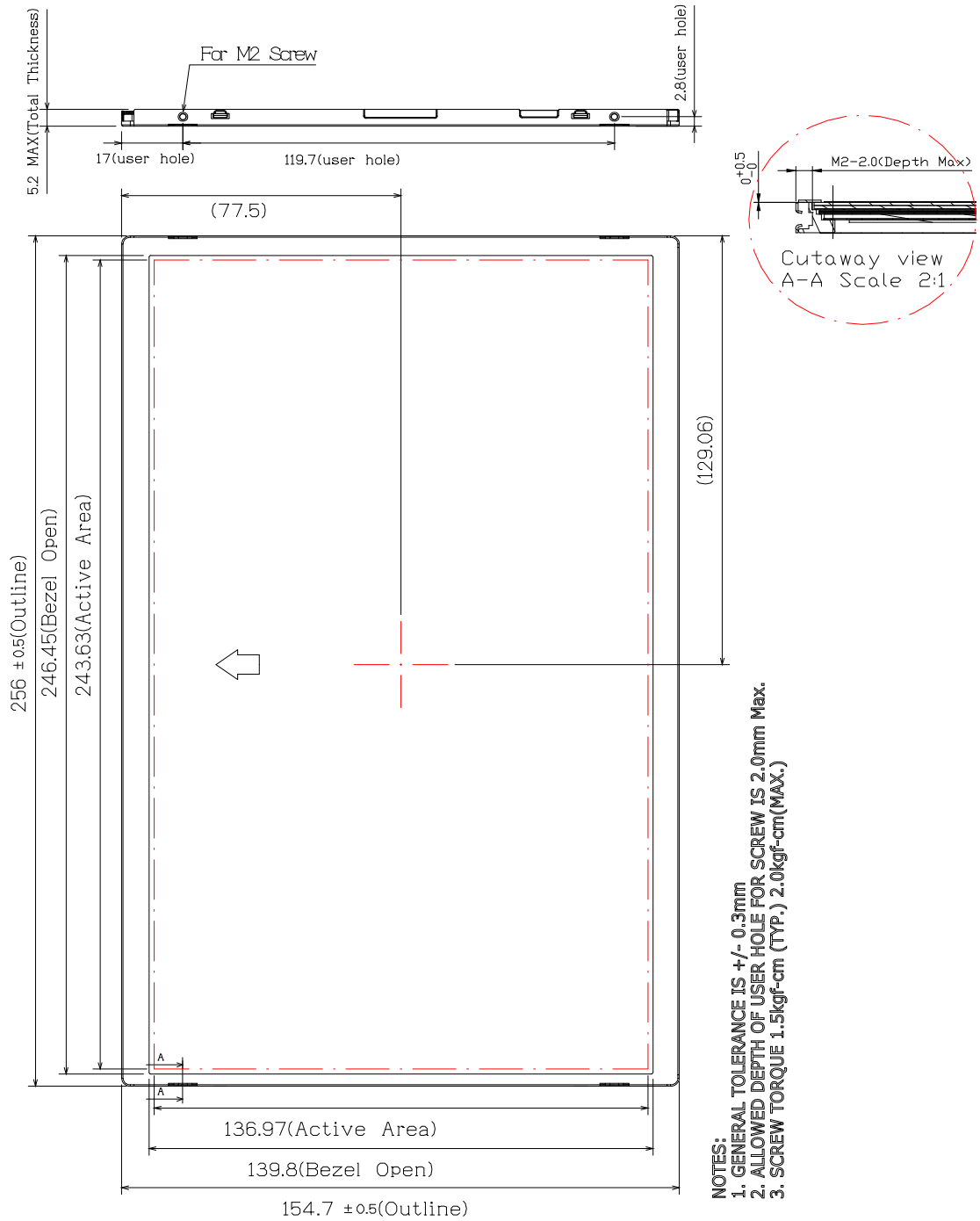

Document Title	HSD110PHW1 Specification	Page No.	23/27
Document No.		Revision	1.0

### 8.2 Back View Outline Dimension

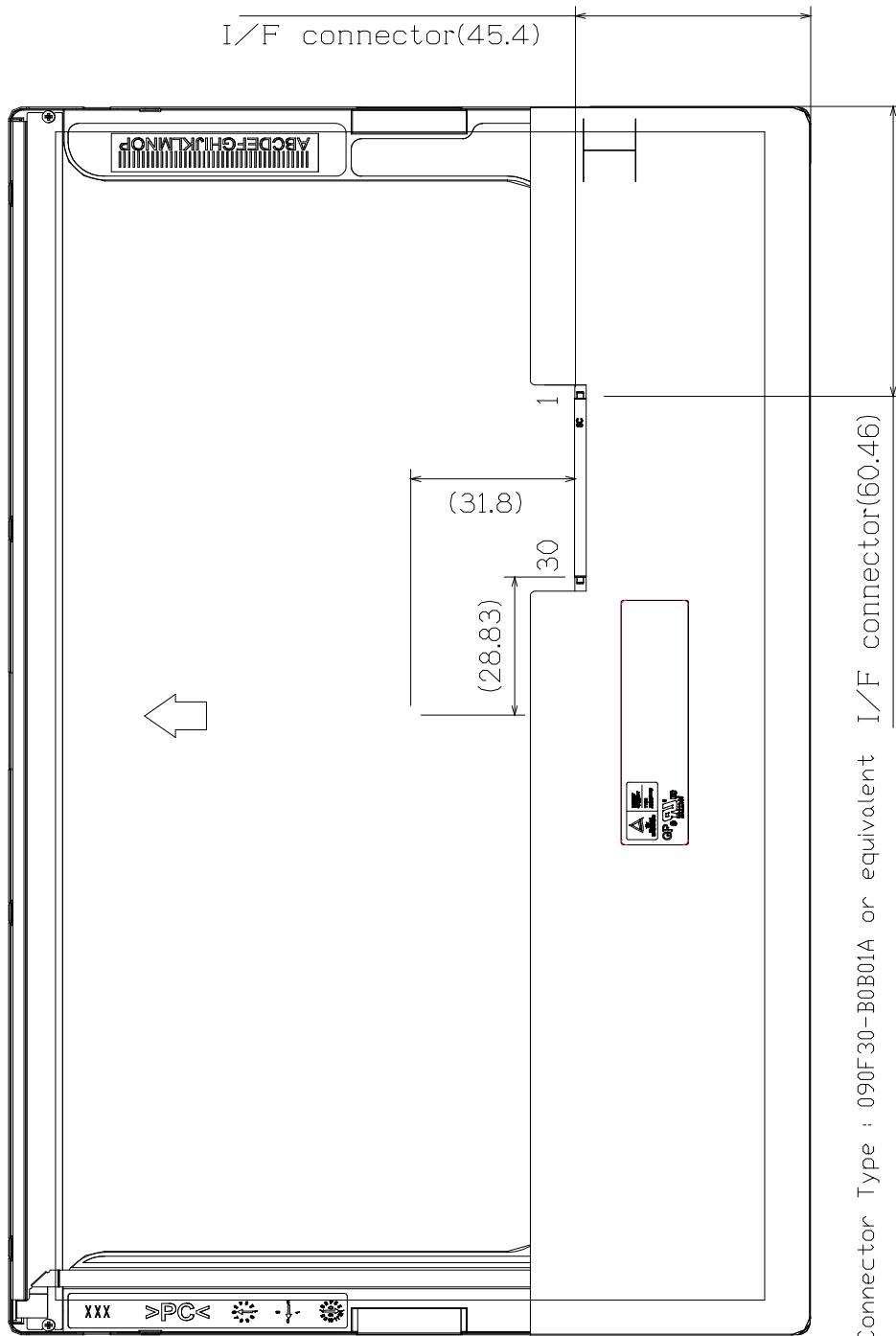

Connector Type : 090F30-B0B01A or equivalent I/F connector(60.46)

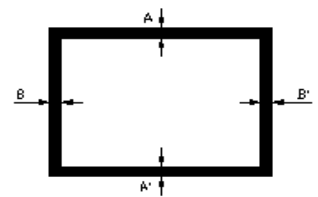

BM Assembly Tolerance  
 $|A-A'| \leq 1 \text{ (mm)}$   
 $|B-B'| \leq 1 \text{ (mm)}$

Document Title	HSD110PHW1 Specification	Page No.	24/27
Document No.		Revision	1.0

## 9.0 LOT MARK

### 9.1 Lot Mark

1	2	3	4	5	6	7	8	9	10	11	12	13	14	15
---	---	---	---	---	---	---	---	---	----	----	----	----	----	----

Code 1,2,3,4,5,6: HannStar internal flow control code.

Code 7: production location.

Code 8: production year.

Code 9: production month.

Code 10,11,12,13,14,15: serial number.

#### Note (1) Production Year

Year	2001	2002	2003	2004	2005	2006	2007	2008	2009	2010
Mark	1	2	3	4	5	6	7	8	9	0

#### Note (2) Production Month

Month	Jan.	Feb.	Mar.	Apr.	May.	Jun.	Jul.	Aug.	Sep.	Oct	Nov.	Dec.
Mark	1	2	3	4	5	6	7	8	9	A	B	C

### 9.2 Location of Lot Mark

(1) The label is attached to the backside of the LCD module.

(2) This is subject to change without prior notice.

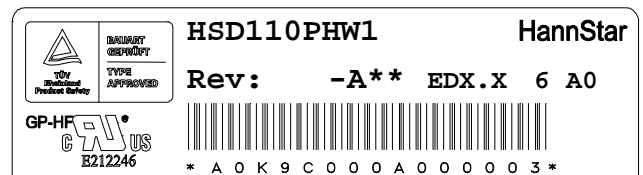
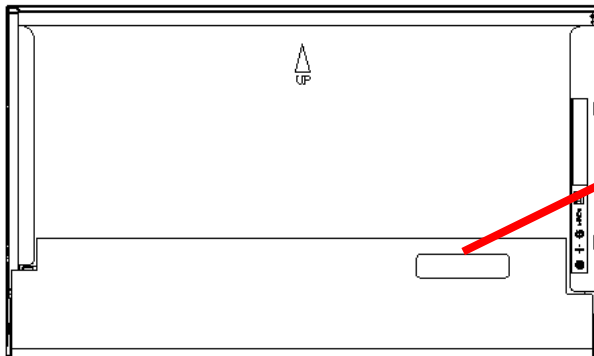

Document Title	HSD110PHW1 Specification	Page No.	25/27
Document No.		Revision	1.0

## 10.0 PACKAGE SPECIFICATION

### 10.1 Packing form

LCM Model	LCM Qty. in the box	Inner Box Size (mm)	Notice
HSD110PHW1-A	50 pcs/box	568 x 314 x 330 <sup>H</sup>	

### 10.2 Packing assembly drawings

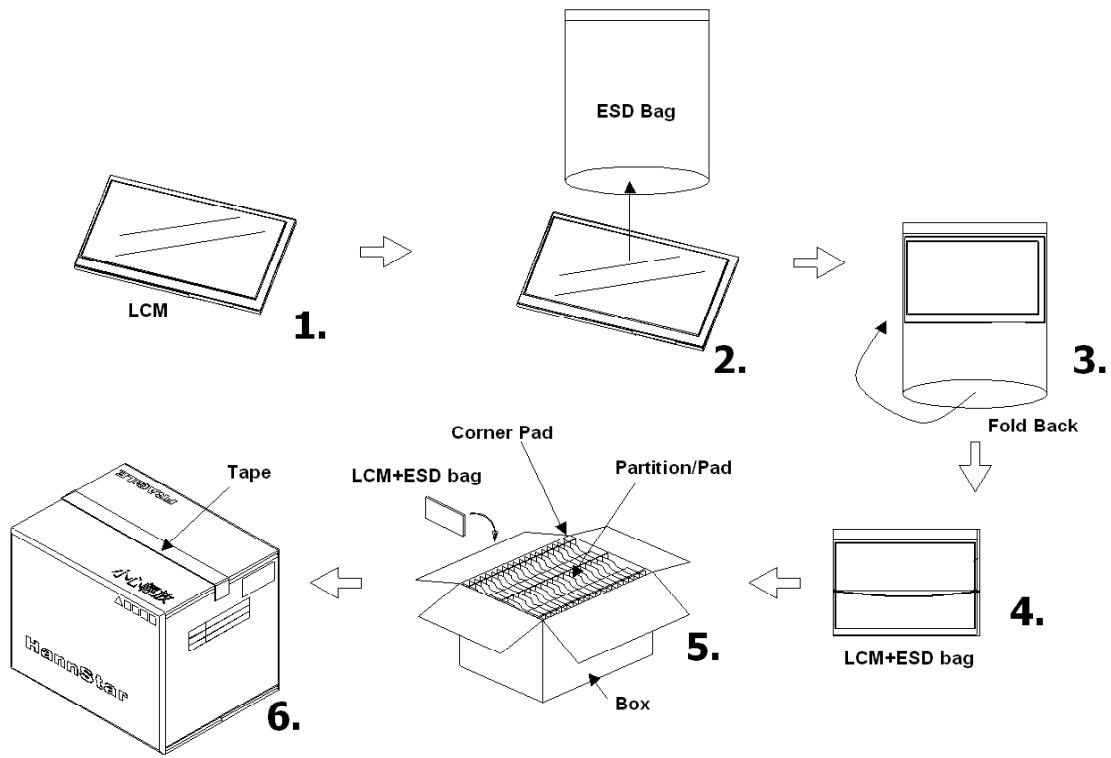

HSD110PHW1-A	Material	Notice
Box	Corrugated Paper Board	(AB Flute)
Partition/Pad	Corrugated Paper Board	(B Flute)
Corner Pad	Corrugated Paper Board	(AB Flute)
ESD bag	PE	--

Document Title	HSD110PHW1 Specification	Page No.	26/27
Document No.		Revision	1.0

## **11.0 GENERAL PRECAUTION**

### **11.1 Use Restriction**

This product is not authorized for use in life supporting systems, aircraft navigation control systems, military systems and any other application where performance failure could be life-threatening or otherwise catastrophic.

### **11.2 Disassembling or Modification**

Do not disassemble or modify the module. It may damage sensitive parts inside LCD module, and may cause scratches or dust on the display. HannStar does not warrant the module, if customers disassemble or modify the module.

### **11.3 Breakage of LCD Panel**

11.3.1. If LCD panel is broken and liquid crystal spills out, do not ingest or inhale liquid crystal, and do not contact liquid crystal with skin.

11.3.2. If liquid crystal contacts mouth or eyes, rinse out with water immediately.

11.3.3. If liquid crystal contacts skin or cloths, wash it off immediately with alcohol and rinse thoroughly with water.

11.3.4. Handle carefully with chips of glass that may cause injury, when the glass is broken.

### **11.4 Electric Shock**

11.4.1. Disconnect power supply before handling LCD module.

11.4.2. Do not pull or fold the LED cable.

11.4.3. Do not touch the parts inside LCD modules and the fluorescent LED's connector or cables in order to prevent electric shock.

### **11.5 Absolute Maximum Ratings and Power Protection Circuit**

11.5.1. Do not exceed the absolute maximum rating values, such as the supply voltage variation, input voltage variation, variation in parts' parameters, environmental temperature, etc., otherwise LCD module may be damaged.

11.5.2. Please do not leave LCD module in the environment of high humidity and high temperature for a long time.

11.5.3. It's recommended to employ protection circuit for power supply.

### **11.6 Operation**

11.6.1 Do not touch, push or rub the polarizer with anything harder than HB pencil lead.

11.6.2 Use fingerstalls of soft gloves in order to keep clean display quality, when persons handle the LCD module for incoming inspection or assembly.

11.6.3 When the surface is dusty, please wipe gently with absorbent cotton or other soft material.

11.6.4 Wipe off saliva or water drops as soon as possible. If saliva or water drops contact with polarizer for a long time, they may causes deformation or color fading.



Document Title	HSD110PHW1 Specification	Page No.	27/27
Document No.		Revision	1.0

11.6.5 When cleaning the adhesives, please use absorbent cotton wetted with a little petroleum benzine or other adequate solvent.

**11.7 Mechanism**

Please mount LCD module by using mounting holes arranged in four corners tightly.

**11.8 Static Electricity**

11.8.1 Protection film must remove very slowly from the surface of LCD module to prevent from electrostatic occurrence.

11.8.2 Because LCD module use CMOS-IC on circuit board and TFT-LCD panel, it is very weak to electrostatic discharge. Please be careful with electrostatic discharge. Persons who handle the module should be grounded through adequate methods.

**11.9 Strong Light Exposure**

The module shall not be exposed under strong light such as direct sunlight. Otherwise, display characteristics may be changed.

**11.10 Disposal**

When disposing LCD module, obey the local environmental regulations.