



Document Title	HSD100IFW1-A** Preliminary Specification	Page No.	1/27
Document No.	DC010-000714	Revision	1.0

TO :

Date : Jan., 28, 2008

HannStar Product Specification **(Preliminary)**

10" Color TFT-LCD Module

Model: HSD100IFW1

-A**

- Note: 1. Please contact HannStar Display Corp. before designing your product based on this module specification.
2. The information contained herein is presented merely to indicate the characteristics and performance of our products. No responsibility is assumed by HannStar for any intellectual property claims or other problems that may result from application based on the module described herein.
3. The mark " ** " of Model means sub-model code.



Document Title	HSD100IFW1-A * * Preliminary Specification	Page No.	2/27
Document No.	DC010-000714	Revision	1.0

Record of Revisions

Rev.	Date	Sub-Model	Description of change
1.0	Jan., 28, 2008	-	Preliminary Product Specification was first released.



Document Title	HSD100IFW1-A** Preliminary Specification	Page No.	3/27
Document No.	DC010-000714	Revision	1.0

Contents

1.0	General description.	p.4
2.0	Absolute maximum ratings	p.5
3.0	Optical characteristics	p.6
4.0	Block diagram	p.10
5.0	Interface pin connection	p.11
6.0	Electrical characteristics	p.13
7.0	Reliability test items.....	p.19
8.0	Outline dimension	p.20
9.0	Lot mark	p.21
10.0	Package specification	p.22
11.0	General precaution	p.23
12.0	EDID Table	p.24

Document Title	HSD100IFW1-A * * Preliminary Specification	Page No.	4/27
Document No.	DC010-000714	Revision	1.0

1.0 GENERAL DESCRIPTION

1.1 Introduction

HannStar Display model HSD100IFW1-A is a color active matrix thin film transistor (TFT) liquid crystal display (LCD) that uses amorphous silicon TFT as a switching device. This model is composed of a TFT LCD panel, a driving circuit and a back light system. This TFT LCD has a 10.0 (17:10) inch diagonally measured active display area with 3072 x 600 dot (1024 horizontal by 600 vertical pixel) resolution.

1.2 Features

- 10 (17:10 diagonal) inch configuration
- One channel LVDS interface
- RoHS Compliance

1.3 Applications

- Mobile NB
- Digital Photo frame
- Display terminal for AV application

1.4 General information

Item	Specification	Unit	
Outline Dimension	235 x 145.8 x 5.5 (Typ.)	mm	
Display area	220.416(H) x 129.15(V)	mm	
Number of Pixel	1024 RGB(H) x600(V)	pixels	
Pixel pitch	0.21525(H) x 0.21525(V)	mm	
Pixel arrangement	RGB Vertical stripe		
Display mode	Normally white		
Surface treatment	Antiglare, Hard-Coating (3H) with EWV film		
Weight	(259.9) (Typ.)	g	
Back-light	Single LED (Side-Light type)		
Power Consumption	Logic System	(36.4)(Typ.)	mW
	B/L System	(1.98)(Max.)	W

1.5 Mechanical Information

Item	Min.	Typ.	Max.	Unit	
Module Size	Horizontal (H)	234.5	235	235.5	mm
	Vertical (V)	145.3	145.8	146.3	mm
	Depth (D)	—	5.5	5.8	mm
Weight (Without inverter)	—	(259.9)	—	g	

Document Title	HSD100IFW1-A** Preliminary Specification	Page No.	5/27
Document No.	DC010-000714	Revision	1.0

2.0 ABSOLUTE MAXIMUM RATINGS

2.1 Electrical Absolute Rating

2.1.1 TFT LCD Module

Item	Symbol	Min.	Max.	Unit	Note
Power supply voltage	V_{DD}	-0.3	5.5	V	GND=0
	V_{GH}	-0.3	15.5	V	GND=0
	V_{GL}	-6.8	0.3	V	GND=0
	$V_{GH} - V_{GL}$	-6.5	15.2	V	
	V_{COM}	-0.3	5.5	V	
Logic Signal Input Level	V_I	-0.3	V_{DD}	V	

2.1.2 Back-Light Unit

Item	Symbol	Typ.	Max.	Unit	Note
LED current	I_L	200	--	mA	(1) (2)
LED voltage	V_L	9.9	10.5	V	(1) (2)(3)

Note (1) Permanent damage may occur to the LCD module if beyond this specification. Functional operation should be restricted to the conditions described under normal operating conditions.

(2) $T_a = 25 \pm 2^\circ\text{C}$

(3) Test Condition: LED current 200 mA

2.2 Environment Absolute Rating

Item	Symbol	Min.	Max.	Unit	Note
Operating Temperature	T_{opa}	-20	70	$^\circ\text{C}$	
Storage Temperature	T_{stg}	-30	80	$^\circ\text{C}$	

Document Title	HSD100IFW1-A** Preliminary Specification	Page No.	6/27
Document No.	DC010-000714	Revision	1.0

3.0 OPTICAL CHARACTERISTICS

3.1 Optical specification

Item		Symbol	Condition	Min.	Typ.	Max.	Unit	Note
Contrast		CR	$\theta=0$ Normal viewing angle	400	500	—		(1)(2)
Response time	Rising	T_R		—	5	7	msec	(1)(3)
	Falling	T_F		—	20	28		
White luminance (Center)		Y_L			200	220	—	cd/m ²
Color chromaticity (CIE1931)	White	W_x	$\theta=0$ Normal viewing angle	0.260	0.310	0.360		(1)(4)
		W_y		0.280	0.330	0.380		
	Green	G_x		0.261	0.311	0.361		
		G_y		0.496	0.546	0.596		
	Blue	B_x		0.102	0.152	0.202		
		B_y		0.091	0.141	0.191		
	Red	R_x		0.532	0.582	0.632		
		R_y		0.299	0.349	0.399		
Viewing angle	Hor.	θ_L	CR>10	70	80	—		
		θ_R		70	80	—		
	Ver.	θ_U		70	80	—		
		θ_D		70	80	—		
Brightness uniformity		B_{UNI}	$\theta=0$	70	—	—	%	(5)
Optima View Direction		6 O' clock						(6)

3.2 Measuring Condition

- Measuring surrounding : dark room
- LED current I_L : 200mA
- Ambient temperature : 25±2°C
- 30min. warm-up time.

Document Title	HSD100IFW1-A** Preliminary Specification	Page No.	7/27
Document No.	DC010-000714	Revision	1.0

3.3 Measuring Equipment

- FPM520 of Westar Display technologies, INC., which utilized SR-3 for Chromaticity and BM-5A for other optical characteristics.

- Measuring spot size : 20 ~ 21 mm

Note (1) Definition of Viewing Angle:

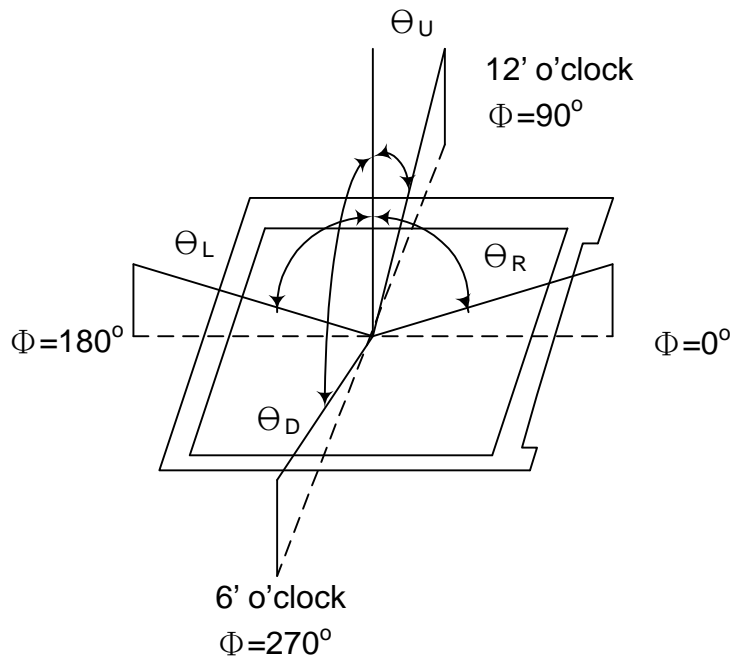

Note (2) Definition of Contrast Ratio (CR) :
measured at the center point of panel

$$CR = \frac{\text{Luminance with all pixels white}}{\text{Luminance with all pixels black}}$$

Document Title	HSD100IFW1-A** Preliminary Specification	Page No.	8/27
Document No.	DC010-000714	Revision	1.0

Note (3) Definition of Response Time : Sum of T_R and T_F

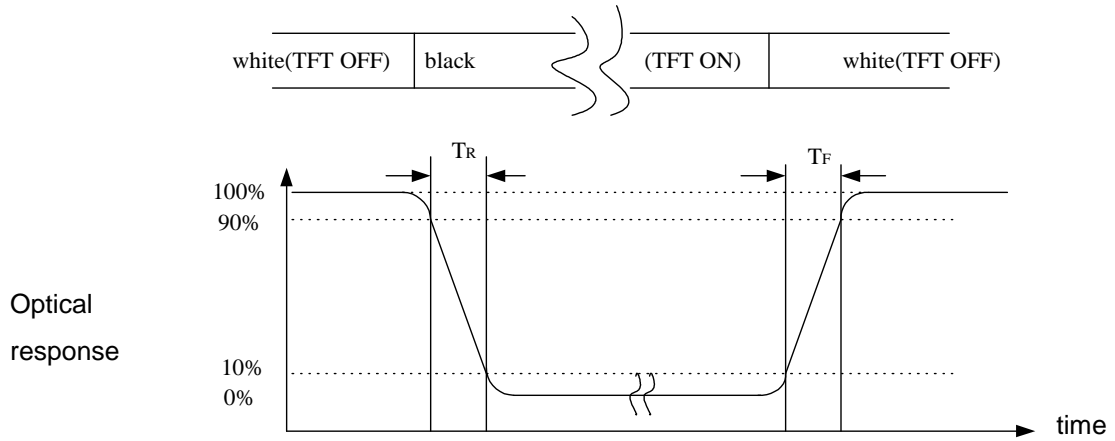

Note (4) Definition of optical measurement setup

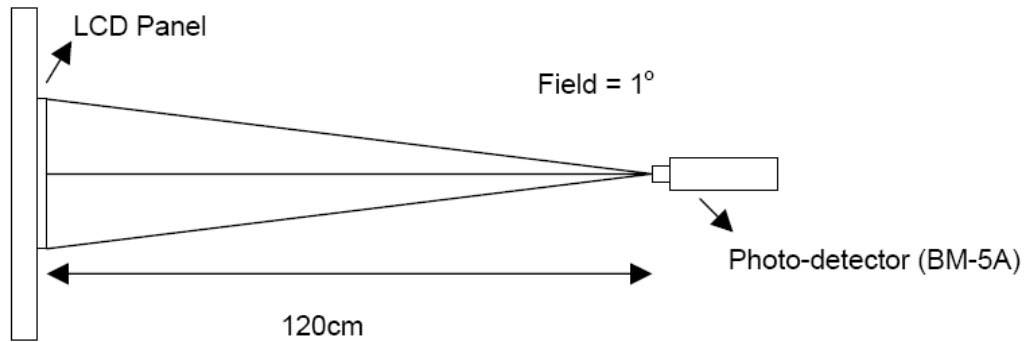

Document Title	HSD100IFW1-A** Preliminary Specification	Page No.	9/27
Document No.	DC010-000714	Revision	1.0

Note (5) Definition of brightness uniformity

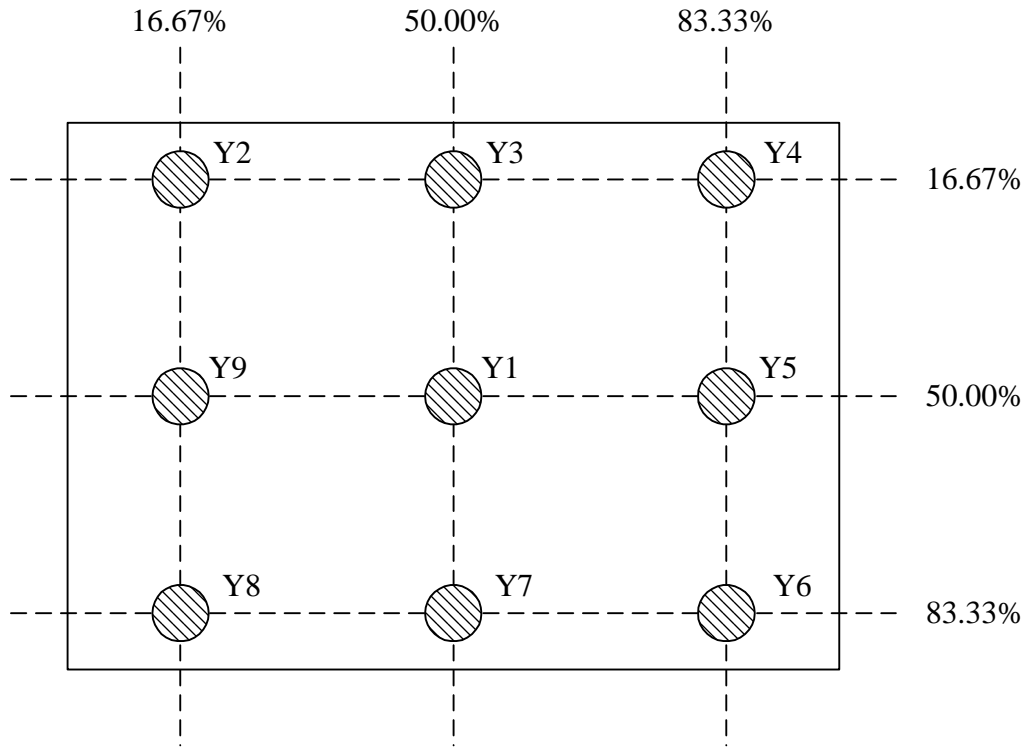

$$\text{Luminance uniformity} = \frac{(\text{Min Luminance of 9 points})}{(\text{Max Luminance of 9 points})} \times 100\%$$

Note (6) : Rubbing Direction (The different Rubbing Direction will cause the different optima view direction.)

Document Title	HSD100IFW1-A** Preliminary Specification	Page No.	10/27
Document No.	DC010-000714	Revision	1.0

4.0 BLOCK DIAGRAM

4.1 TFT LCD Module:

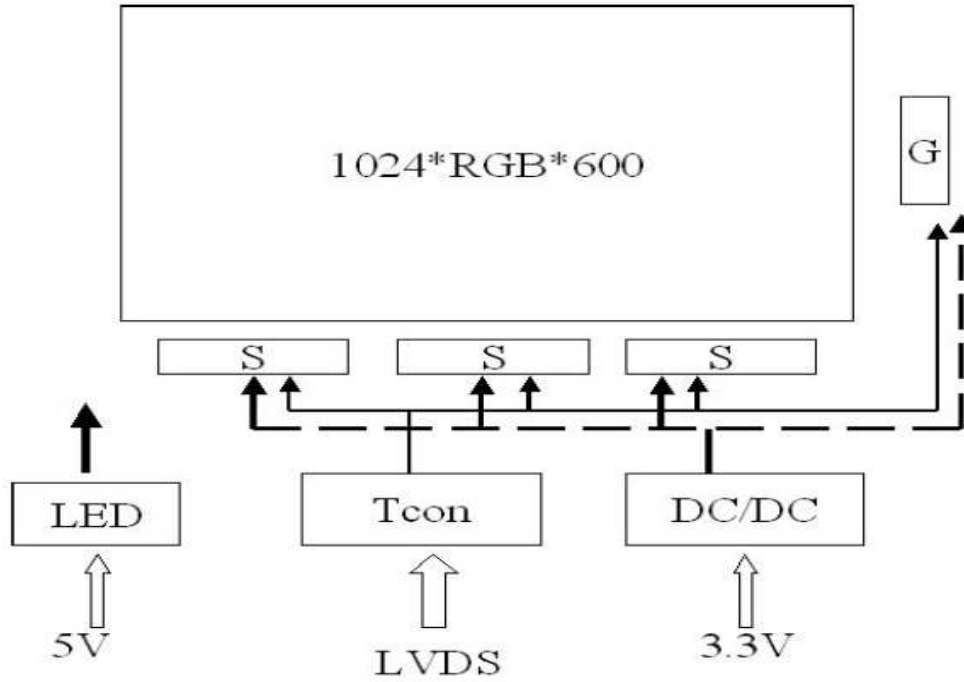

4.2 Pixel Format

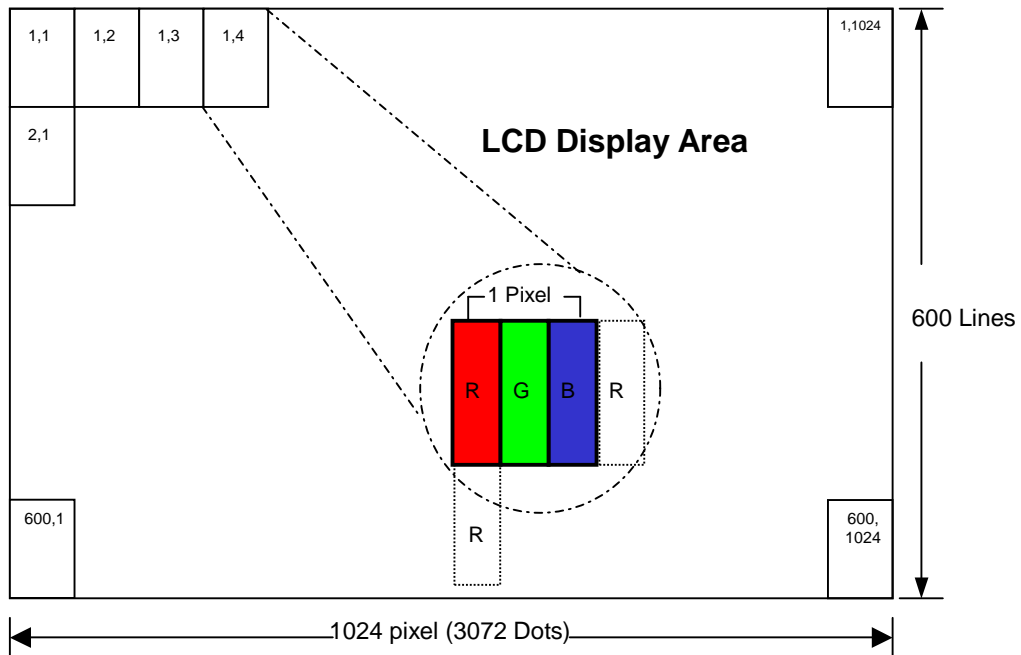

Document Title	HSD100IFW1-A* * Preliminary Specification	Page No.	11/27
Document No.	DC010-000714	Revision	1.0

5.0 INTERFACE PIN CONNECTION

5.1 TFT LCD Module :

CN1 (Input signal): LVDS 30PINS PITCH:1mm

Pin No.	Signal	Description
1	GND	Ground
2	VCC	3.3V Power
3	VCC	3.3V Power
4	V_EDID	3.3V Power for NB
5	ADJ	Adjust for LED brightness Note
6	CLK_EDID	EDID Clock for NB
7	DATA_EDID	EDID Data for NB
8	RXIN0-	LVDS Signal - channel0-
9	RXIN0+	LVDS Signal+ channel0+
10	GND	Ground
11	RXIN1-	Data Input channel1-
12	RXIN1+	Data Input channel1+
13	GND	Ground
14	RXIN2-	Data Input channel2-
15	RXIN2+	Data Input channel2+
16	GND	Ground
17	RXCLKIN-	Data Input CLK-
18	RXCLKIN+	Data Input CLK+
19	GND	Ground
20	NC	NC for RXIN3- channel3-
21	NC	NC for RXIN3+ channel3+
22	GND	Ground
23	GND	Ground
24	VLED	LED Power 5V
25	VLED	LED Power 5V
26	VLED	LED Power 5V
27	NC	
28	NC	
29	NC	
30	NC	

Note : The brightness of LCD panel could be changed by adjusting ADJ

Document Title	HSD100IFW1-A** Preliminary Specification	Page No.	12/27
Document No.	DC010-000714	Revision	1.0

【Note】

1) ADJ adjust brightness to control Pin · Pulse duty the bigger the brighter.

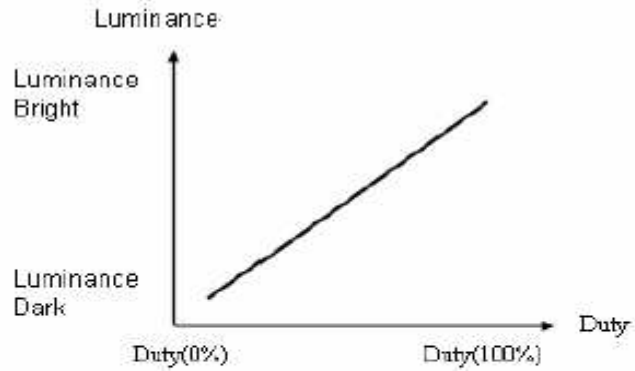

2) ADJ signal=0~3.3V · operation frequency : 20KHZ

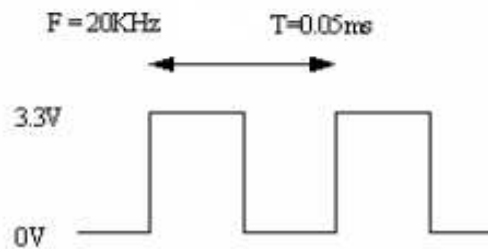

Document Title	HSD100IFW1-A** Preliminary Specification	Page No.	13/27
Document No.	DC010-000714	Revision	1.0

6.0 ELECTRICAL CHARACTERISTICS

6.1 TFT LCD Module

Item	Symbol	Min.	Typ.	Max.	Unit	Note
Supply Voltage	DV_{DD}	3.0	3.3	3.6	V	
	V_{GH}	-	15.5	-	V	
	V_{GL}	-	-6.8	-	V	
	AV_{DD}	-	11	-	V	
VCOM	V_{CAC}	-	5.5	-	VP-P	AC component
	V_{CDC}	-	-	-	V	DC component, (1)
Input signal voltage	V_{IH}	0.7 DV_{DD}	-	DV_{DD}	V	
	V_{iL}	0	-	0.3 DV_{DD}	V	
Current of power supply	I_{DD}	-		-	uA	$DV_{DD}=3.3V$
	I_{ADD}	-		-	mA	$AV_{DD}=11V(\text{Black})$
	I_{GH}	-		-	uA	$V_{GH}=15.5V$
	I_{GL}	-		-	uA	$V_{GL}=-6.8V$

Note (1) : The brightness of LCD panel could be changed by adjusting ADJ.

Document Title	HSD100IFW1-A** Preliminary Specification	Page No.	14/27
Document No.	DC010-000714	Revision	1.0

6.2 Timing Diagram of Interface Signal

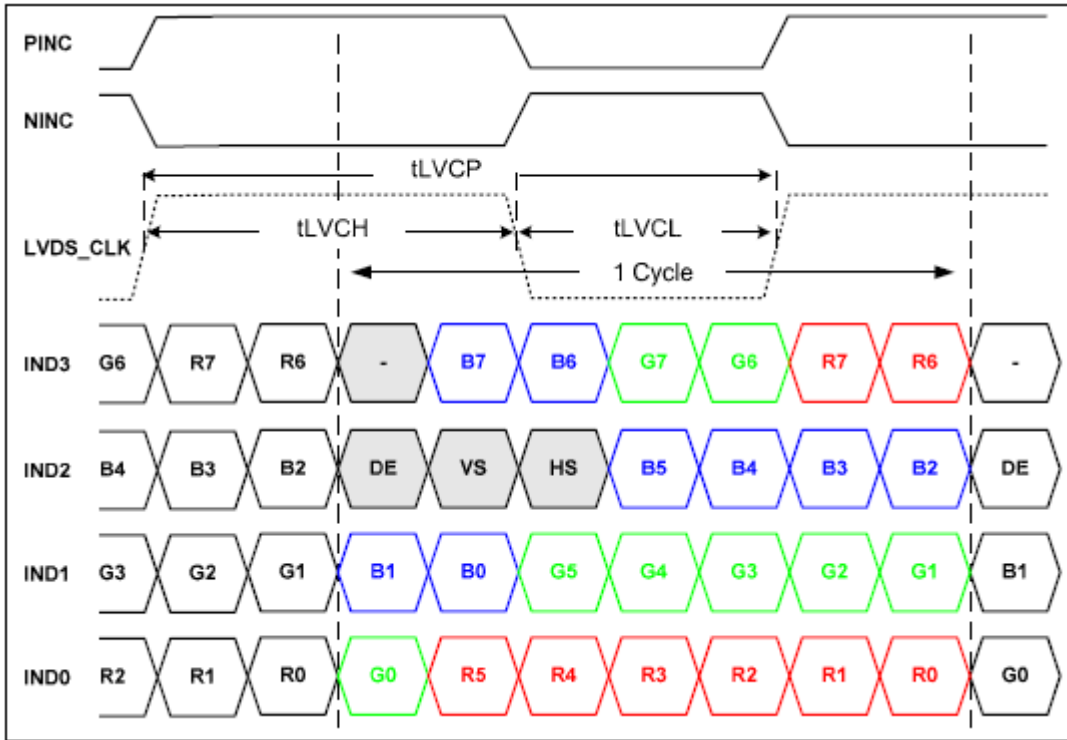

for 6bits LVDS input

for 8bits LVDS input

IND0= channel0 RXIN0-/+
 IND1= channel1 RXIN1-/+
 IND2= channel2 RXIN2-/+
 IND3= channel3 function off

IND0= channel0 RXIN0-/+
 IND1= channel1 RXIN1-/+
 IND2= channel2 RXIN2-/+
 IND3= channel3 RXIN3-/+
 (need change BOM for 8bits)

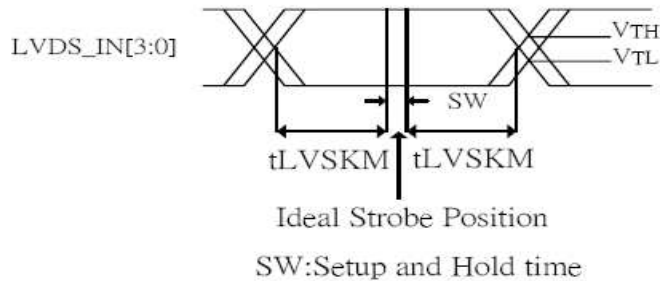

Document Title	HSD100IFW1-A** Preliminary Specification	Page No.	15/27
Document No.	DC010-000714	Revision	1.0

Output Timing Characteristics

Vertical output timing diagram

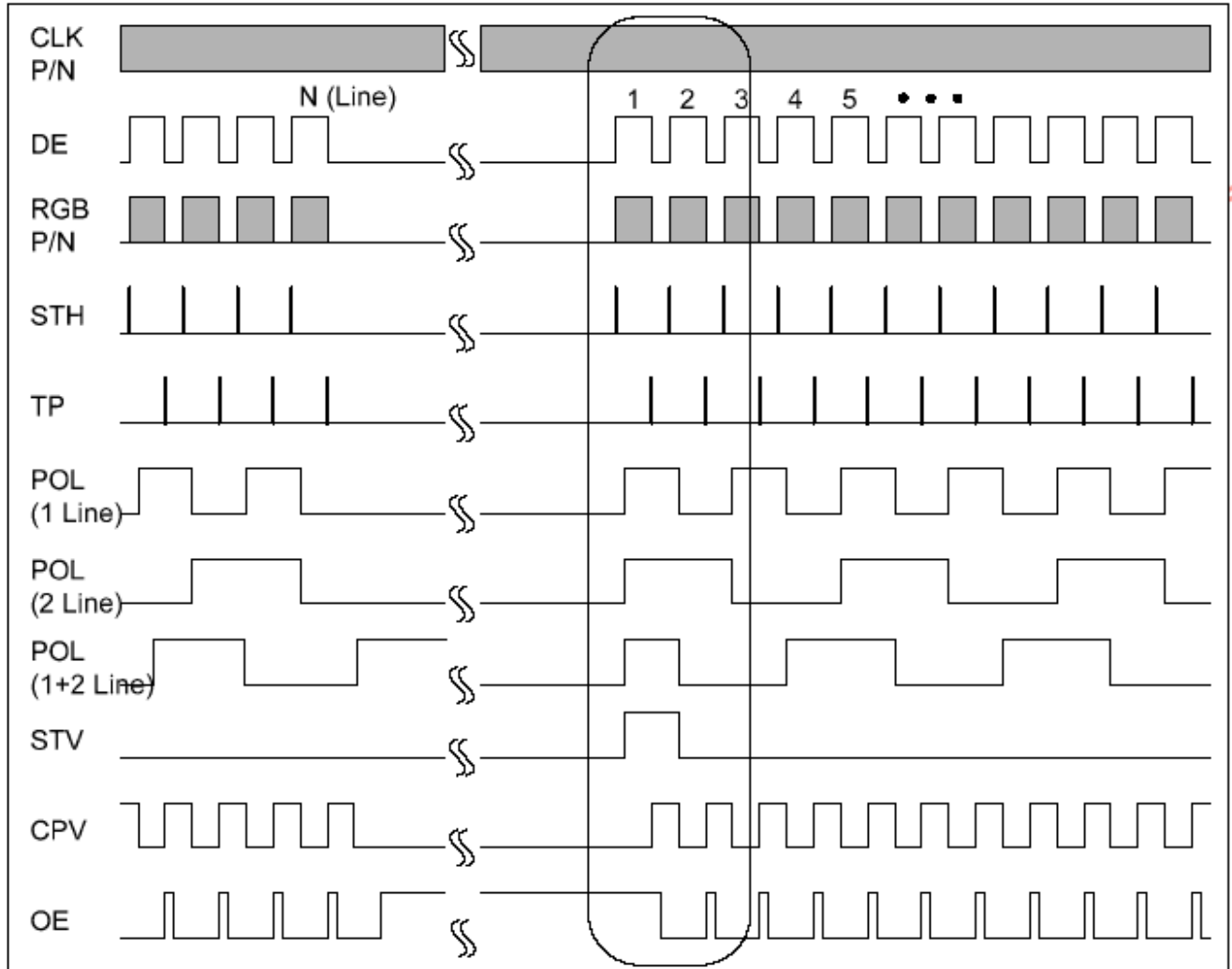

Document Title	HSD100IFW1-A** Preliminary Specification	Page No.	16/27
Document No.	DC010-000714	Revision	1.0

Horizontal output timing diagram

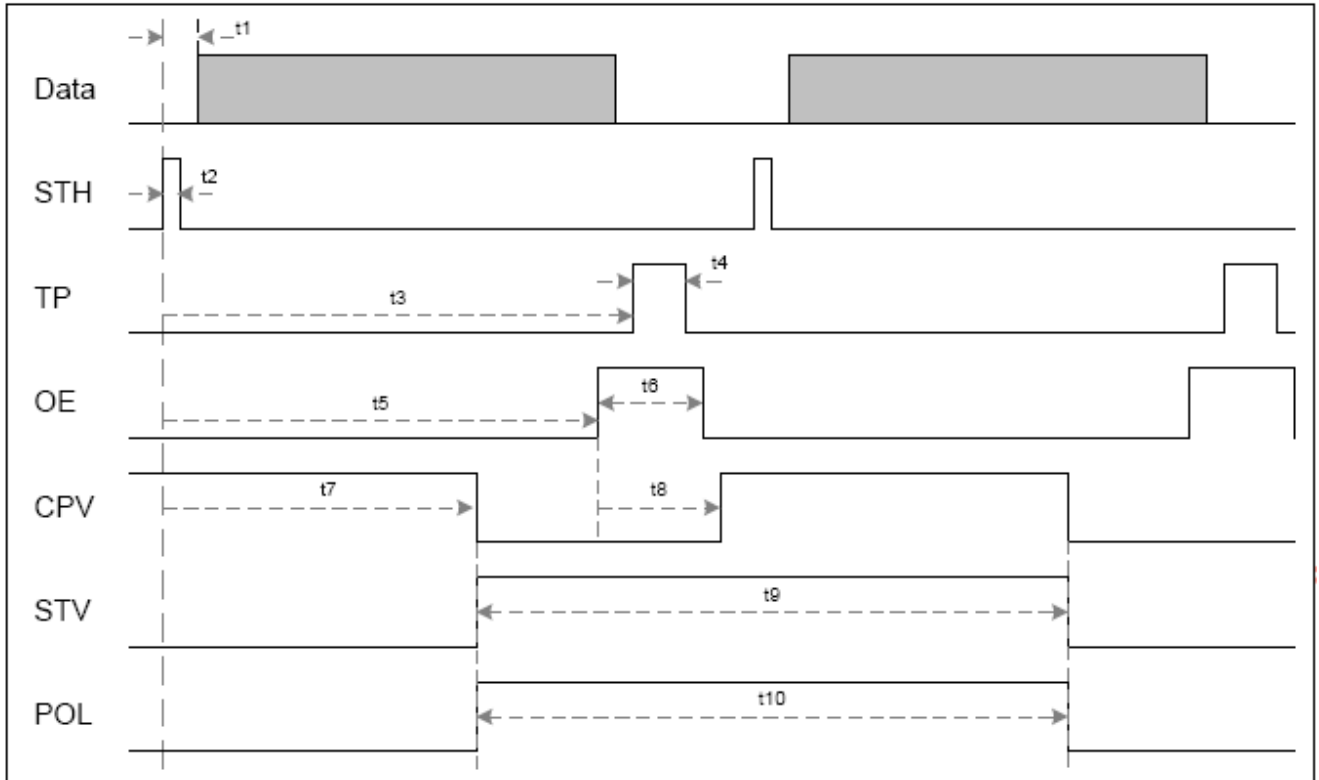

Document Title	HSD100IFW1-A** Preliminary Specification	Page No.	17/27
Document No.	DC010-000714	Revision	1.0

6.4 Power Sequence

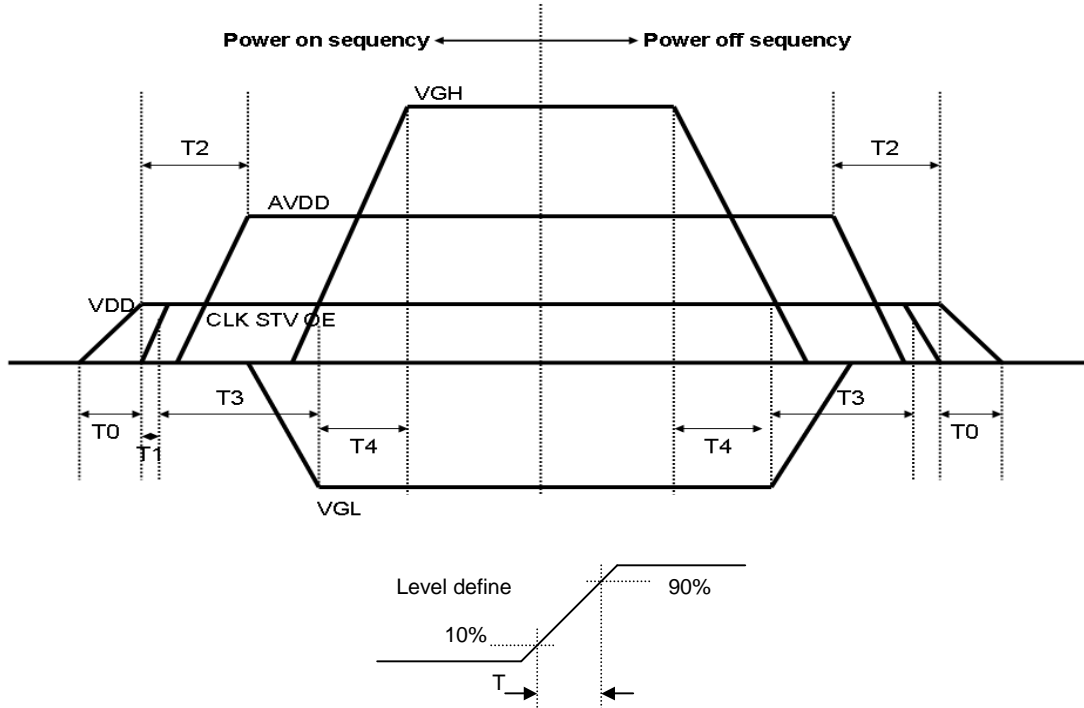

Power On Sequence : $V_{DD} \rightarrow AVDD \rightarrow VGL \rightarrow VGH$

Power Off Sequence : $VGH \rightarrow VGL \rightarrow AVDD \rightarrow V_{DD}$

Power on Sequence

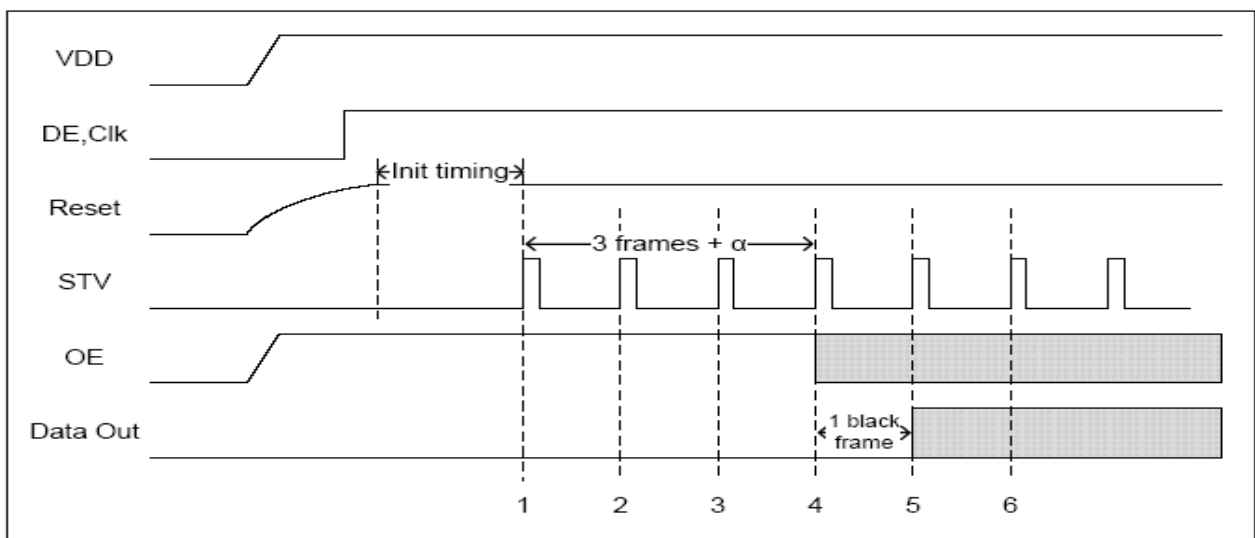

Document Title	HSD100IFW1-A** Preliminary Specification	Page No.	18/27
Document No.	DC010-000714	Revision	1.0

7.0 Reliability test items

No.	Item	Conditions	Remark
1	High Temperature Storage	Ta=+80°C, 240hrs	
2	Low Temperature Storage	Ta=-30°C, 240hrs	
3	High Temperature Operation	Ta=+70°C, 240hrs	
4	Low Temperature Operation	Ta=-20°C, 240hrs	
5	High Temperature and High Humidity (operation)	Ta=+60°C, 90%RH, 240hrs	
6	Thermal Cycling Test (non operation)	-30°C(30min) → +80°C(30min), 200 cycles	
7	Electrostatic Discharge	±200V,200pF(0Ω) 1 time/each terminal	
8	Vibration	1.Random: 1.04G, 10~500Hz, X/Y/Z, 30min/each direction 2.Sweep sine: 1.5G, 5~500Hz, X/Y/Z, 30min/each direction	
9	Shock	100G, 6ms, ±X, ±Y, ±Z 3 time for each direction	JIS C7021, A-10 (Condition A)
10	Vibration (with carton)	Random: 1.04G, 10~500Hz, X/Y/Z 45min/each direction Fixed: 1.5G, 5Hz, X/Y/Z 45min/each direction	
11	Drop (with carton)	Height : 60 cm 1 corner, 3 edges, 6 surfaces	JIS Z0202 (1)

Note: There is no display function NG issue occurred, all the cosmetic specification is judged before the reliability stress.

Document Title	HSD100IFW1-A** Preliminary Specification	Page No.	19/27
Document No.	DC010-000714	Revision	1.0

8.0 OUTLINE DIMENSION

Unit : mm

8.1 Outline Dimension



- NOTE:
1. GENERAL TOLERANCE : $\pm 0.3\text{mm}$.
 2. ALLOWED DEPTH OF USERHOLE SCREW INSERTION IS 1.5mm Max.
 3. USERHOLE SCREW OF TORQUE = 1.0kgf/cm Max.

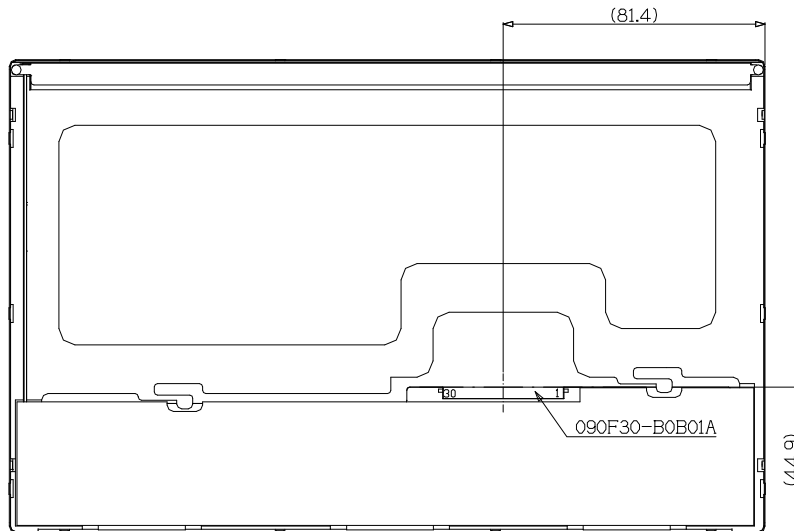

Document Title	HSD100IFW1-A** Preliminary Specification	Page No.	20/27
Document No.	DC010-000714	Revision	1.0

9.0 LOT MARK

9.1 Lot Mark

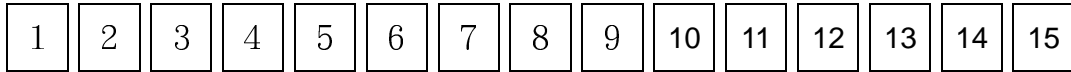

Code 1,2,3,4,5,6: HannStar internal flow control code.

Code 7: production location.

Code 8: production year.

Code 9: production month.

Code 10,11,12,13,14,15: serial number.

Note (1) Production Year

Year	1999	2000	2001	2002	2003	2004	2005	2006	2007	2008
Mark	9	0	1	2	3	4	5	6	7	8

Note (2) Production Month

Month	Jan.	Feb.	Mar.	Apr.	May.	Jun.	Jul.	Aug.	Sep.	Oct	Nov.	Dec.
Mark	1	2	3	4	5	6	7	8	9	A	B	C

9.2 Location of Lot Mark

(1) The label is attached to the backside of the LCD module.

(2) This is subject to change without prior notice.

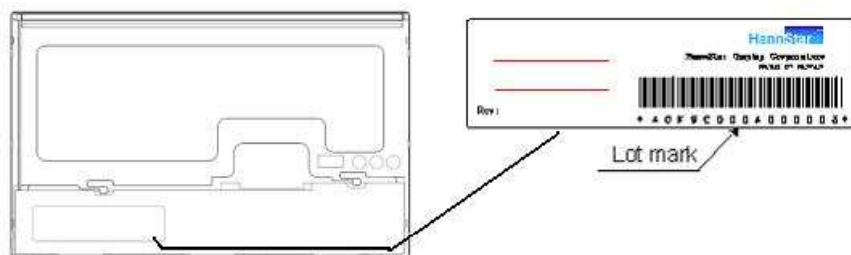

Document Title	HSD100IFW1-A** Preliminary Specification	Page No.	21/27
Document No.	DC010-000714	Revision	1.0

10.0 PACKAGE SPECIFICATION

10.1 Packing form

- (1) Package quantity in one carton: 30 pieces.
- (2) Carton size: 460±3 mm×361±3 mm×321±3 mm.
- (3) For domestic transportation only.

10.2 Packing assembly drawings

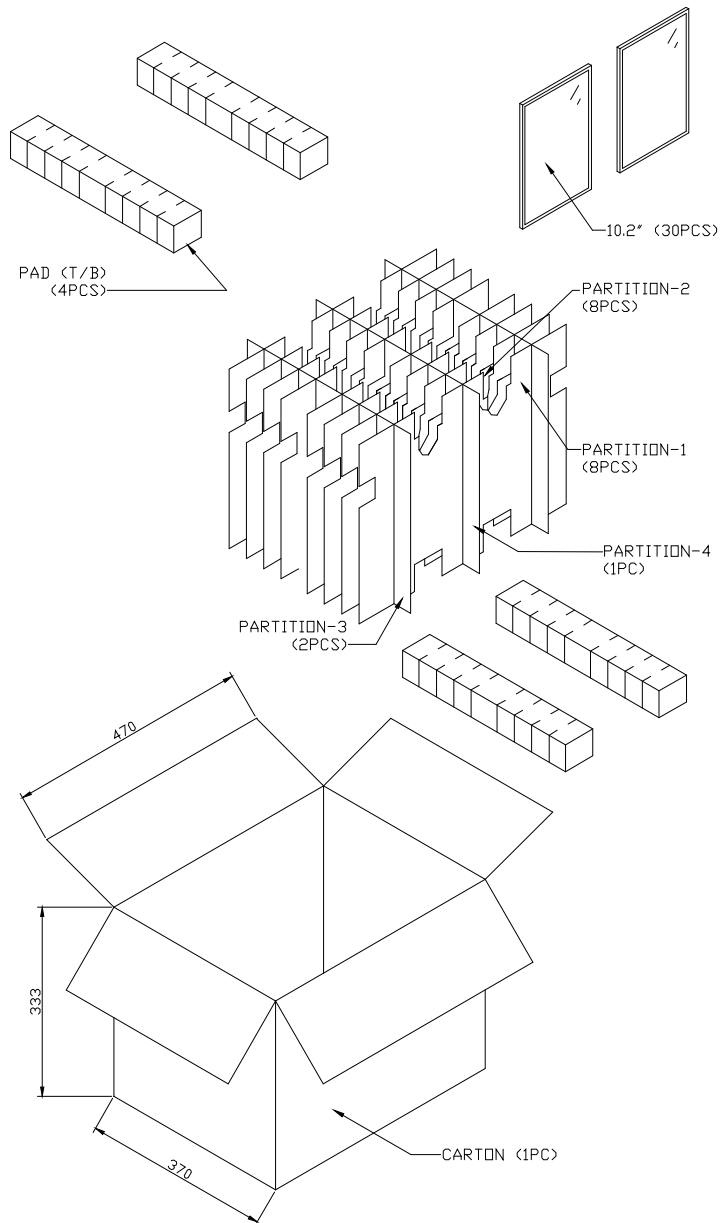



Document Title	HSD100IFW1-A** Preliminary Specification	Page No.	22/27
Document No.	DC010-000714	Revision	1.0

11.0 GENERAL PRECAUTION

11.1 Use Restriction

This product is not authorized for use in life supporting systems, aircraft navigation control systems, military systems and any other application where performance failure could be life-threatening or otherwise catastrophic.

11.2 Disassembling or Modification

Do not disassemble or modify the module. It may damage sensitive parts inside LCD module, and may cause scratches or dust on the display. HannStar does not warrant the module, if customers disassemble or modify the module.

11.3 Breakage of LCD Panel

11.3.1. If LCD panel is broken and liquid crystal spills out, do not ingest or inhale liquid crystal, and do not contact liquid crystal with skin.

11.3.2. If liquid crystal contacts mouth or eyes, rinse out with water immediately.

11.3.3. If liquid crystal contacts skin or cloths, wash it off immediately with alcohol and rinse thoroughly with water.

11.3.4. Handle carefully with chips of glass that may cause injury, when the glass is broken.

11.4 Electric Shock

11.4.1. Disconnect power supply before handling LCD module.

11.4.2. Do not pull or fold the LED cable.

11.4.3. Do not touch the parts inside LCD modules and the fluorescent LED's connector or cables in order to prevent electric shock.

11.5 Absolute Maximum Ratings and Power Protection Circuit

11.5.1. Do not exceed the absolute maximum rating values, such as the supply voltage variation, input voltage variation, variation in parts' parameters, environmental temperature, etc., otherwise LCD module may be damaged.

11.5.2. Please do not leave LCD module in the environment of high humidity and high temperature for a long time.

11.5.3. It's recommended to employ protection circuit for power supply.

11.6 Operation

11.6.1 Do not touch, push or rub the polarizer with anything harder than HB pencil lead.

11.6.2 Use fingerstalls of soft gloves in order to keep clean display quality, when persons handle the LCD module for incoming inspection or assembly.

11.6.3 When the surface is dusty, please wipe gently with absorbent cotton or other soft material.



Document Title	HSD100IFW1-A** Preliminary Specification	Page No.	23/27
Document No.	DC010-000714	Revision	1.0

11.6.4 Wipe off saliva or water drops as soon as possible. If saliva or water drops contact

with polarizer for a long time, they may causes deformation or color fading.

11.6.5 When cleaning the adhesives, please use absorbent cotton wetted with a little petroleum benzine or other adequate solvent.

11.7 Mechanism

Please mount LCD module by using mounting holes arranged in four corners tightly.

11.8 Static Electricity

11.8.1 Protection film must remove very slowly from the surface of LCD module to prevent from electrostatic occurrence.

11.8.2. Because LCD module use CMOS-IC on circuit board and TFT-LCD panel, it is very

weak to electrostatic discharge. Please be careful with electrostatic discharge.

Persons who handle the module should be grounded through adequate methods.

11.9 Strong Light Exposure

The module shall not be exposed under strong light such as direct sunlight. Otherwise, display characteristics may be changed.

11.10 Disposal

When disposing LCD module, obey the local environmental regulations.



Document Title	HSD100IFW1-A** Preliminary Specification	Page No.	24/27
Document No.	DC010-000714	Revision	1.0

12.0 EDID Table (Contents of the table will be defined by customers.)

Byte# (Decimal)	Byte# (HEX)	Field Name & Comments	Value (HEX)	Value (BIN)	Value (DEC)
0	0				
1	1				
2	2				
3	3				
4	4				
5	5				
6	6				
7	7				
8	8				
9	9				
10	0A				
11	0B				
12	0C				
13	0D				
14	0E				
15	0F				
16	10				
17	11				
18	12				
19	13				
20	14				
21	15				
22	16				
23	17				
24	18				
25	19				
26	1A				
27	1B				
28	1C				
29	1D				
30	1E				
31	1F				



Document Title	HSD100IFW1-A** Preliminary Specification	Page No.	25/27
Document No.	DC010-000714	Revision	1.0

Byte# (Decimal)	Byte# (HEX)	Field Name & Comments	Value (HEX)	Value (BIN)	Value (DEC)
32	20				
33	21				
34	22				
35	23				
36	24				
37	25				
38	26				
39	27				
40	28				
41	29				
42	2A				
43	2B				
44	2C				
45	2D				
46	2E				
47	2F				
48	30				
49	31				
50	32				
51	33				
52	34				
53	35				
54	36				
55	37				
56	38				
57	39				
58	3A				
59	3B				
60	3C				
61	3D				
62	3E				
63	3F				
64	40				



Document Title	HSD100IFW1-A** Preliminary Specification	Page No.	26/27
Document No.	DC010-000714	Revision	1.0

Byte# (Decimal)	Byte# (HEX)	Field Name & Comments	Value (HEX)	Value (BIN)	Value (DEC)
65	41				
66	42				
67	43				
68	44				
69	45				
70	46				
71	47				
72	48				
73	49				
74	4A				
75	4B				
76	4C				
77	4D				
78	4E				
79	4F				
80	50				
81	51				
82	52				
83	53				
84	54				
85	55				
86	56				
87	57				
88	58				
89	59				
90	5A				
91	5B				
92	5C				
93	5D				
94	5E				
95	5F				
96	60				
97	61				



Document Title	HSD100IFW1-A** Preliminary Specification	Page No.	27/27
Document No.	DC010-000714	Revision	1.0

Byte# (Decimal)	Byte# (HEX)	Field Name & Comments	Value (HEX)	Value (BIN)	Value (DEC)
98	62				
99	63				
100	64				
101	65				
102	66				
103	67				
104	68				
105	69				
106	6A				
107	6B				
108	6C				